



IMPORTANT
READ CAREFULLY BEFORE USE
KEEP SAFE FOR LATER REFERENCE

Spedelec

Maintenance and operating instructions

EN

E-Stream EVO 45 AM

G18

Copyright

© ZEG Zweirad-Einkaufs-Genossenschaft eG

Distribution or reproduction of these operating instructions and utilisation or communication of their content is prohibited unless expressly approved. Any infringement will render the offender liable for compensation. All rights reserved in the event that a patent, utility model or industrial design is registered.

Table of contents

1	About these instructions	6
1.1	Manufacturer	6
1.2	Laws, standards and directives	7
1.3	Other valid documents	7
1.4	Subject to change	7
1.5	Identifying	8
1.5.1	Operating instructions	8
1.5.2	Vehicle	8
1.6	For your safety	9
1.6.1	Instruction, training and customer service	9
1.6.2	Basic safety notes	10
1.6.3	Warnings	10
1.6.4	Safety markings	11
1.7	For your information	11
1.7.1	Instructions for actions	11
1.7.2	Information on the type plate	11
1.7.3	Language conventions	12
1.8	Nameplate	14
2	Safety	15
2.1	Requirements for the rider	15
2.2	Personal protective equipment	15
2.3	Hazards for vulnerable groups	15
2.4	Duty of care	15
2.4.1	Rider	15
2.4.2	User	16
2.5	Proper use	17
2.6	Improper use	18
3	Description	19
3.1	Overview	19
3.2	Handlebars	20
3.3	Wheel and fork	21
3.3.1	Valve	21
3.3.2	Suspension	22
3.3.2.1	Fork structure	24
3.3.2.2	Rear frame damper structure	25
3.4	Brake system	26
3.5	Electric drive system	27

3.5.1	Headlight	29
3.5.2	Horn	29
3.5.3	Display	30
3.5.3.1	USB port	31
3.5.3.2	Screen displays	31
3.5.4	Command console	34
3.5.5	Rear and brake light	35
3.5.6	Battery	35
3.5.6.1	Operating and charge status indicator	36
4	Technical data	37
4.1	Vehicle	37
4.2	Battery	37
4.3	Display	38
4.4	Emissions	38
4.5	USB port	38
4.6	Fork	39
4.7	Brake	41
4.8	Tyres	42
4.9	Headlight	42
4.10	Tightening torque	43
5	Transportation, storage and assembly	46
5.1	Transportation	46
5.1.1	Using the transport securing system	48
5.2	Storing	48
5.2.1	Break in operation	49
5.2.1.1	Preparing a break in operation	50
5.2.1.2	Carrying out break in operation	50
5.3	Assembly	51
5.3.1	Unpacking	52
5.3.2	Scope of delivery	52
5.3.3	Commissioning	53
5.3.3.1	Initial commissioning check list	54
5.3.3.2	Checking the battery	55
5.3.3.3	Sell vehicle	55
6	Adjust vehicle to rider	56
6.1	Saddle	56
6.1.1	Determining the seat height	56
6.1.2	Clamping the seat post	57
6.1.3	Adjusting the sitting position and saddle tilt	58

6.2	Setting the handlebars	58
6.3	Brake lever	59
6.3.1	Adjusting the pressure point	59
6.3.2	Setting grip distance	60
6.4	Suspension and damping	61
6.4.1	Adjusting the suspension	61
6.4.1.1	Front wheel	62
6.4.1.2	Rear wheel	65
6.4.2	Setting the rebound damper	67
6.4.2.1	Front wheel	68
6.4.3	Setting the compression damper	70
6.4.3.1	Front wheel	70
6.4.3.2	Rear wheel	71
6.5	Retracting brake linings	71
7	Operation	72
7.1	Before each ride	74
7.1.1	Check list before each ride	75
7.2	Using the kickstand	76
7.2.1	Raising the kickstand	76
7.2.2	Parking the vehicle	76
7.3	Battery	77
7.3.1	Removing the battery	79
7.3.2	Inserting the battery	79
7.3.3	Charging the battery	80
7.3.4	Waking the battery	82
7.4	Electric drive system	83
7.4.1	Switching on the electric drive system	83
7.4.2	Switching off the electric drive system	83
7.5	Command console with display	84
7.5.1	Display	84
7.5.1.1	Removing the display	84
7.5.1.2	Attaching the display	84
7.5.2	Using the USB port	85
7.5.3	Using the push assist	85
7.5.4	Selecting the level of assistance	86
7.5.5	Switching journey information	86
7.5.6	Changing the system information	87
7.6	Gear shift	88
7.6.1	Using the gear shift	88
7.7	Brakes	89

7.7.1	Braking	90
7.8	Horn	90
7.8.1	Sounding the horn	90
7.9	Suspension and damping	91
7.9.1	Fork	91
7.9.1.1	Locking the fork lock	91
7.9.1.2	Opening the fork lock	92
7.10	Rear frame damper	92
7.10.1	Activating the threshold setting	92
7.10.2	Activating the lock setting	92
7.1.1	Wheel	94
7.1.1	Closing the quick release	95
8	Maintenance	97
8.1	Cleaning and servicing	99
8.1.1	After every ride	99
8.1.1.1	Cleaning the fork	99
8.1.1.2	Cleaning the pedals	99
8.1.2	Basic cleaning	100
8.1.2.1	Cleaning the frame	101
8.1.2.2	Clean rear frame damper	101
8.1.2.3	Cleaning the wheel	101
8.1.2.4	Cleaning the drive elements	101
8.1.2.5	Cleaning the chain	102
8.1.2.6	Cleaning the battery	102
8.1.2.7	Cleaning the brake	103
8.1.2.8	Cleaning the display	103
8.1.3	Servicing	104
8.1.3.1	Servicing the frame	104
8.1.3.2	Servicing the fork	104
8.1.3.3	Servicing the drive elements	104
8.1.3.4	Servicing the pedal	104
8.1.3.5	Servicing the chain	104
8.1.3.6	Servicing the drive elements	104
8.2	Maintenance	105
8.2.1	Checking the wheel	105
8.2.1.1	Checking tyre pressure	105
8.2.1.2	Checking the tyres	105
8.2.1.3	Checking the rims	106
8.2.2	Checking the brake system	106
8.2.2.1	Checking for damage	106

8.2.2.2	Checking the brake linings for wear	106
8.2.2.3	Checking the pressure point	107
8.2.2.4	Checking the brake discs for wear	107
8.2.3	Checking the electrical cables and brake cables	107
8.2.4	Checking the gear shift	107
8.2.5	Checking the chain tension	108
8.2.6	Checking the handlebar grip position	108
8.2.7	Checking the USB port cover	109
8.3	Service	110
8.4	Adjusting and repairing	111
8.4.1	Use original parts and lubricants only	111
8.4.2	Rear frame damper	112
8.4.3	Fork	114
8.4.4	Wheel quick release	115
8.4.4.1	Setting the clamping force	115
8.4.5	Brake	116
8.4.6	Lighting	117
8.4.6.1	Replacing the lighting	117
8.4.6.2	Setting the headlight	117
8.4.7	Tyre	117
8.4.7.1	Adjust tyre pressure	117
8.4.7.2	Puncture and protect tyre	118
8.4.8	Repair by the specialist dealer	119
8.4.9	System messages	120
8.4.9.1	First aid	121
8.4.9.2	Specific error eradication	121
8.4.10	First aid	122
8.4.10.1	Electrical drive system does not start	122
8.5	Accessories	124
9	Recycling and disposal	125
10	Appendix	127
10.1	Parts and repair list	127
10.2	Table of figures	130
10.3	List of tables	132
10.4	Index	133

1

About these instructions

Read these operating instructions before commissioning the vehicle to ensure you use all the functions correctly and safely. They are not a substitute for personal training by the supplying ZEG specialist dealer. The operating instructions are an integral part of the vehicle. Therefore, if it is re-sold at a later time, they must be handed over to the subsequent owner.

These operating instructions are mainly intended for the rider and user of the vehicle, who tend to be non-professionals.



Text passages which are expressly intended for specialist staff (e.g. bicycle mechanics) are clearly marked with a tool symbol.

Staff at all ZEG specialist dealers have specialist training and qualifications. They are thus capable of identifying risks and preventing hazards which may arise during maintenance, servicing and repairs on the vehicle. Information for specialist staff does not require non-professionals to take any action.

1.1

Manufacturer

The vehicle manufacturer is:

ZEG Zweirad-Einkaufs-Genossenschaft eG
Longericher Strasse 2
50739 Köln, Germany

Tel.: +49 221 17959 0

Fax: +49 221 1795931

E-mail: info@zeg.de

Website: www.zeg.de

1.2 **Laws, standards and directives**

These operating instructions comply with the essential requirements from:

- EC Directive No. 168/2013
- Electromagnetic Compatibility Directive 2014/30/EU,
- EN 82079-1:2012, Preparation of instructions for use – Structuring, content and presentation – Part 1: General principles and detailed requirements,
- EN ISO 17100:2016-05, Translation Services – Requirements for translation service.

1.3 **Other valid documents**

These operating instructions are only complete in conjunction with the other applicable documents. The following document applies for this product:

- Charger operating instructions and
- assembly and repair instructions.

No other information is also applicable. The constantly updated lists of approved accessories and parts are available to ZEG specialist dealers.

1.4 **Subject to change**

The information contained in these operating instructions are the approved technical specifications at the time of printing. Any significant changes will be included in a new version of the operating instructions.

You will find any changes to these operating instructions at:

www.bulls.de/service/downloads

1.5 Identifying

1.5.1 Operating instructions

The identification number of these operating instructions is made up of the document number, the version number and the release date. It can be found on the cover page and in the footer.

Identification number	34-03141_1.0_11.06.2018
------------------------------	-------------------------

Table 1: Identification number of the operating instructions

1.5.2 Vehicle

These BULLS operating instructions refer to the *model year* 2018. They were issued in April 2018. The production period is from April to December 2018.

The operating instructions are an integral part of the S pedelec.

<i>Type number</i>	<i>Model</i>
G 18	E-Stream Evo 45 AM

Table 2: Type number and model categorisation

1.6

For your safety

The vehicle's safety concept comprises four elements:

- rider and/or user instruction, and vehicle maintenance and repair by the ZEG specialist dealer,
- the chapter on general safety,
- the warnings in these instructions and
- the safety marking on the type plates.

1.6.1

Instruction, training and customer service

The ZEG specialist dealer and supplier provides customer service. Contact details can be found on the back page of these operating instructions and in the data sheet. If you are unable to contact your specialist dealer, you will find further ZEG specialist dealers on www.zeg.de. They will also be able to attend to your customer service needs.



The ZEG specialist dealer commissioned to perform repairs and maintenance work receives regular training.

The rider or the user of the vehicle will be instructed in person on the vehicle functions when the supplying ZEG specialist dealer hands over the vehicle, if not before. This instruction particularly covers the vehicle's electrical functions and correct use of the charger.

Each rider to whom this vehicle is provided must receive instruction on the vehicle's functions. These operating instructions must be submitted to each rider in printed form and must be acknowledged and adhered to.

1.6.2 Basic safety notes

These operating instructions have a chapter with general safety notes [▶ *Chapter 2, page 15*]. The chapter stands out because of its grey background.

1.6.3 Warnings

Hazardous situations and actions are marked with warnings. The warnings in these operating instructions are shown as follows:

SIGNAL WORD	Type and source of the danger
	Description of the danger and the consequences.
	▶ Measures
	The following pictograms and signal words are used in the operating instructions for warnings and information notices:
	Will lead to serious or even fatal injuries if ignored. High-risk hazard.
	May lead to serious or even fatal injuries if ignored. Medium-risk hazard.
	May lead to minor or moderate injuries. Low-risk hazard.
	May lead to material damage if ignored.

Type and source of the danger

Description of the danger and the consequences.

▶ Measures

The following pictograms and signal words are used in the operating instructions for warnings and information notices:



DANGER

Will lead to serious or even fatal injuries if ignored. High-risk hazard.



WARNING

May lead to serious or even fatal injuries if ignored. Medium-risk hazard.



CAUTION

May lead to minor or moderate injuries. Low-risk hazard.

NOTICE

May lead to material damage if ignored.

Table 3:

Meanings of the signal words

1.6.4**Safety markings**

The following safety markings are used on the charger's type plate:



General warning



Adhere to the instructions for use

Table 4:

Safety markings on the product**1.7****For your information****1.7.1****Instructions for actions**

Instructions for actions are structured in accordance with the following pattern:

- ✓ Requirements (optional)
- ▶ Instruction for action
- ⇒ Result of the action (optional)

1.7.2**Information on the type plate**

Alongside the warnings, product type plates also contain other important information on the vehicle:



Read the instructions



Separate collection of electrical and electronic devices



Separate collection of batteries



Must not be thrown into fire (burning prohibited)

Table 5:

Information on the type plate



Must not be thrown into water (immersed)



Device of protection class II



Only suitable for use indoors



Fuse (device fuse)



EU conformity



Recyclable material

Table 5:

Information on the type plate

1.7.3

Language conventions

The vehicle described in these operating instructions may be equipped with alternative components. The vehicle equipment is defined by the respective type number. If applicable, the notes *alternative equipment* and *alternative version* make reference to the use of alternative components.

The following terms are used for better legibility:

Term	Meaning
Vehicle	S pedelec
Motor	Drive motor

Table 6:

Simplified terms

The following conventions are used in these operating instructions:

Convention	Use
<i>Italics</i>	Entry in the index

Table 7:

Conventions

Convention	Use
SPACED	Displays on the <i>display screen</i>
[▷ <i>Example, page numbering</i>]	Cross references
•	Bulleted lists

Table 7:

Conventions

1.8

Nameplate

The nameplate is located on the *frame*. The nameplate features the following information:

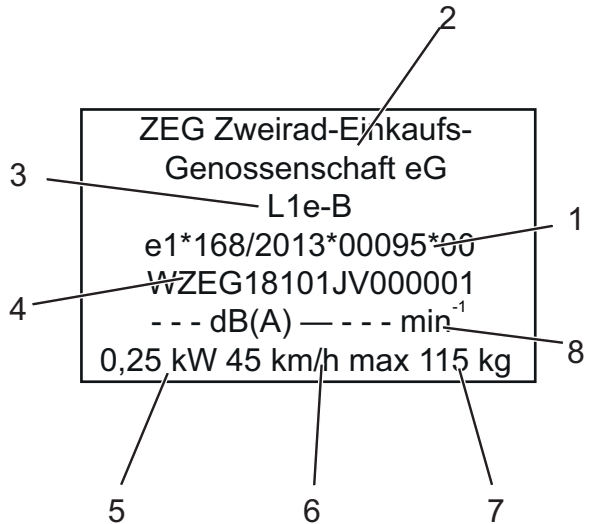

Figure 1:

Type plate, example

- 1 EU type-approval number
- 2 Manufacturer
- 3 Vehicle class
- 4 Vehicle identification number
- 5 Motor power
- 6 Design-related top speed
- 7 Permitted total weight
- 8 Stationary noise

2

Safety

2.1

Requirements for the rider

Unless any other statutory requirements apply to the rider, we recommend that riders be at least 15 years old and hold an AM category driver's licence as a minimum.

2.2

Personal protective equipment

Wearing a helmet is compulsory (moped motor cycle helmet). We also recommend that you wear typical, close-fitting cycling clothing, sturdy footwear and gloves.

2.3

Hazards for vulnerable groups

The battery and the charger must be kept out of the reach of children.

2.4

Duty of care

Vehicle safety can only be assured if all necessary measures are taken.

2.4.1

Rider

The rider:

- receives instruction before the first ride. They can clarify any questions relating to the operating instructions with the user or the ZEG specialist dealer.
- wears personal protective equipment.
- assumes all the user's obligations if the vehicle is passed on to someone else.

2.4.2

User

The user has the duty of care and responsibility for scheduling these measures and checking that they are implemented.

The user:

- makes these operating instructions available to the rider for the duration of vehicle usage. If necessary, they translate the operating instructions into a language which the rider understands.
- familiarises the rider with the vehicle's functions before the first ride. Only riders who have received instruction may be allowed to ride.
- instructs the rider on proper use and the wearing of personal protective equipment.
- employs only specialist staff for maintenance and repair of the vehicle.

The EU type-approval number printed on the type plate is only valid if the vehicle remains intact in its original state. As soon as the user makes any relevant modifications or additions, they legally become the manufacturer. They must carry out the conformance procedure with Commission Implementing Regulation (EU) No. 901/2014 again under their own responsibility.

2.5

Proper use

The vehicle must only be used in perfect, fully functional condition. National requirements may apply to the vehicle which differ from the standard equipment. The general laws and regulations for the prevention of accidents and environmental protection in the respective country of use must be observed. Proper use also includes all instructions for actions and check lists in these operating instructions. Approved accessories can be installed by specialist staff.

The vehicle is designed for daily, convenient use on asphalted roads and paths. The vehicle is suitable for use in road traffic. For riding on public roads, some special regulations apply in relation to *running light*, *reflectors* and other components.

The vehicle is not a sports bicycle. If used for sports, the rider can expect reduced riding stability and diminished comfort. The vehicle is unsuitable for riding on off-road terrain.

2.6

Improper use

Failure to adhere to the proper use poses a risk of personal injury and material damage. The vehicle is not suitable for the following uses:

- manipulating hardware and software,
- riding on cycle paths,
- riding with a damaged or incomplete vehicle,
- riding over steps,
- riding through deep water,
- lending the vehicle to untrained riders,
- carrying further passengers,
- riding with excessive luggage,
- riding with no hands,
- riding on ice and snow,
- improper servicing,
- improper repair,
- demanding areas of use, such as professional competition, and
- stunt riding or acrobatics.

3 Description

3.1 Overview

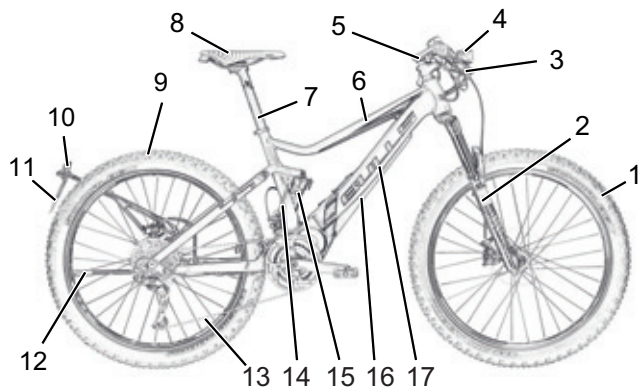

Figure 2:

Vehicle on the right – E-Stream Evo 45 AM

- 1 Front wheel
- 2 Fork
- 3 Handlebars
- 4 Headlight
- 5 Stem
- 6 Frame
- 7 Seat post
- 8 Saddle
- 9 Rear wheel
- 10 Reflector, rear and brake light
- 11 Registration plate
- 12 Kickstand
- 13 Chain
- 14 Vehicle identification number
- 15 Rear frame damper
- 16 Battery
- 17 Nameplate

3.2

Handlebars

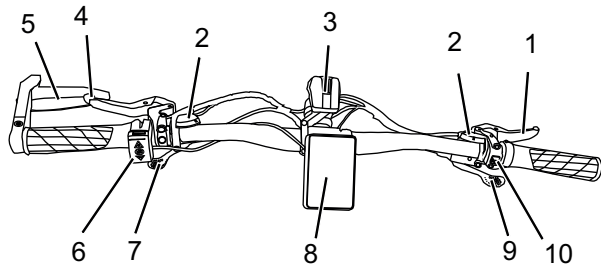

Figure 3:

Detailed view of vehicle from rider position, example

- 1 Front brake lever
- 2 Gear indicator
- 3 Headlight
- 4 Rear brake lever
- 5 Mirror
- 6 Command console
- 7 Front shifter
- 8 Display
- 9 Rear shifter
- 10 Horn

3.3

Wheel and fork

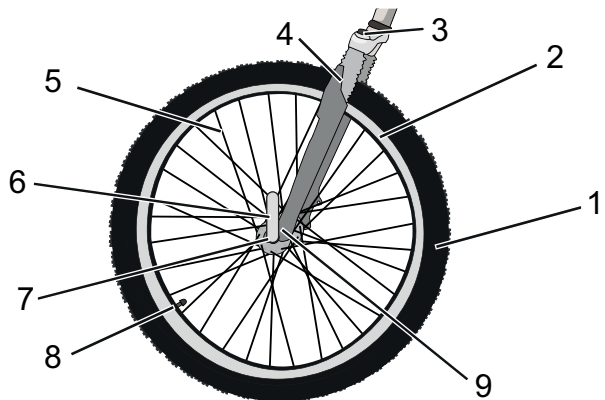

Figure 4:

Wheel components, example of front wheel

- | | |
|---|--------------------------------|
| 1 | Tyre |
| 2 | Rim |
| 3 | Fork head with setting wheel |
| 4 | Shock absorber |
| 5 | Spoke |
| 6 | Quick release |
| 7 | Hub |
| 8 | Valve |
| 9 | Fork end of the shock absorber |

3.3.1

Valve

Each wheel has a valve. It is used to fill the *tyre* with air. There is a valve cap on each valve. The screw-on valve cap keeps out dust and dirt.

The vehicle has a *Schrader valve*.

3.3.2

Suspension

A suspension fork has two functions which improve floor contact and comfort: suspension and damping.



Figure 5:

Vehicle without suspension (tension load) and with suspension (2) when riding over an obstacle

The suspension prevents impacts such as those caused by a stone lying in the vehicle's path from being channelled directly into the rider's body via one of the forks. The impact is absorbed by the suspension system instead. This causes the fork to compress. Compression can be disabled, so that a fork responds like a rigid fork. The compressed fork then returns to its original position. The rear frame damper decelerates movement, preventing the suspension system from springing back in an uncontrolled manner, and the fork from vibrating up and down.

Dampers which dampen rebound deflection movements, i.e. compensate rebound load, are called rebound dampers or rebound dashpots.

Dampers which dampen the compressive deflection movements, i.e. compensate the compressive load, are called compression dampers or compression dashpots.

The rebound damper controls the suspension rebound speed after deflection. The suspension rebound speed

affects the wheel's contact with the ground, which, in turn, has an influence on control and efficiency. The damper should rebound fast enough to sustain traction without producing an erratic or bumpy sensation. If rebound damping is too strong, the damper is unable to rebound fast enough before the next impact.

The higher the compression damper is set, the smaller the fork movement is in the open position. The rebound setting can also be used to prevent dipping and brake pitching when subject to hard loads.

3.3.2.1

Fork structure

The vehicle's fork features air suspension, a compression damper and a rebound damper.

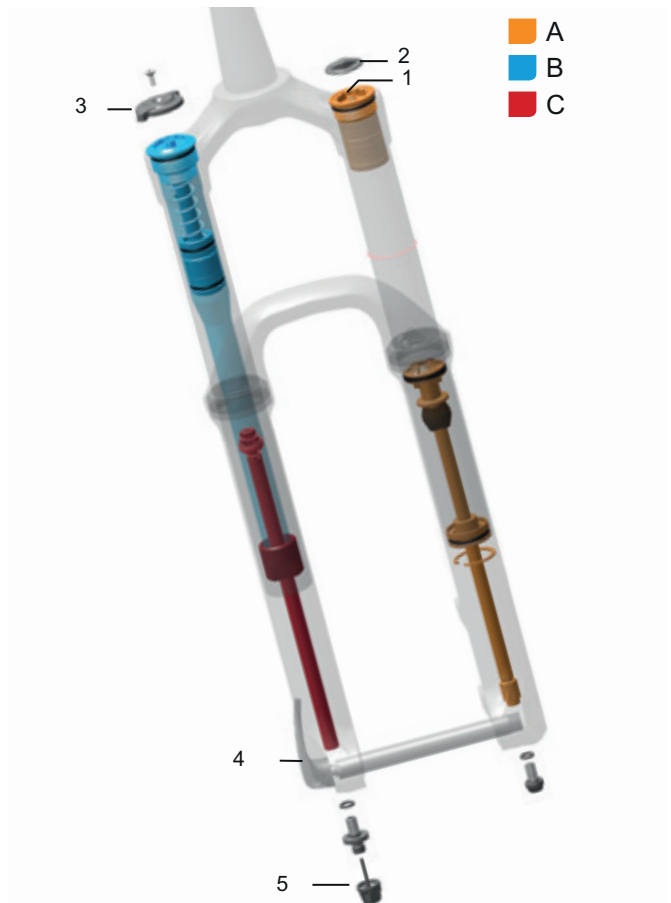

Figure 6: Yari fork – diagram with control elements: Air valve (1), valve cap (2) fork lock (3), quick release (4) and rebound damper adjuster (5) and the assembly groups: Air suspension fork (A), compression damper assembly group (B) and rebound damper assembly group (C)

3.3.2.2

Rear frame damper structure

The rear frame damper features air suspension, a compression damper and a rebound damper.

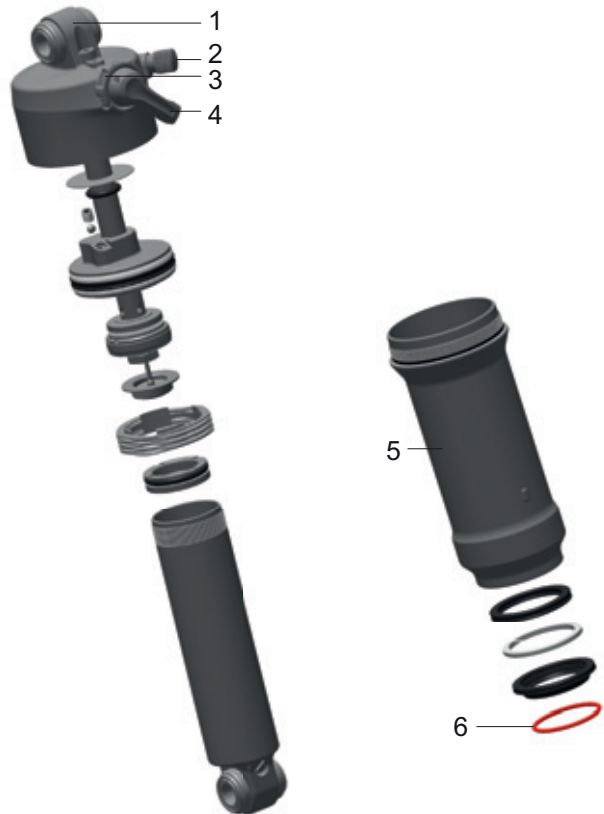

Figure 7:

Exploded view drawing of RockShox Deluxe RT rear frame damper

- 1 Guide rod eye
- 2 Air valve
- 3 Setting wheel
- 4 Lever
- 5 Air chamber
- 6 O-ring

3.4

Brake system

The vehicle is equipped with a hydraulic disk brake.

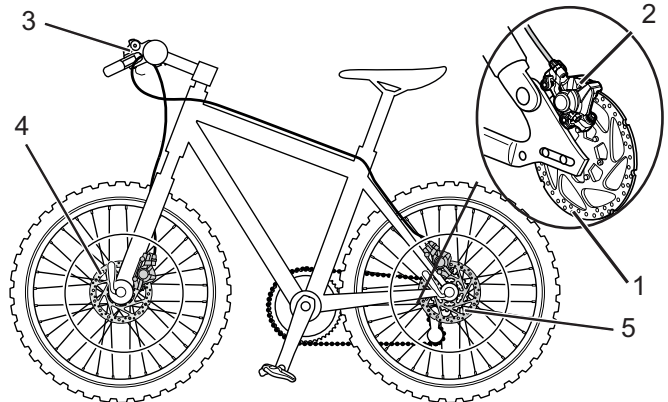

Figure 8:

Vehicle brake system with a disk brake, example

- 1 Brake disc
- 2 Brake caliper with brake linings
- 3 *Handlebars with brake levers*
- 4 Front wheel brake disc
- 5 Rear wheel brake disc

The brake disc is screwed permanently to the wheel *hub* on a vehicle with a disc brake.

The brake lever is pulled to increase brake pressure. The brake fluid is used to transfer pressure through the brake lines to the 4 cylinders in the brake caliper. The braking force is boosted by a speed reduction and applied to 4 brake linings. These apply the brake disc mechanically. If the brake lever is pulled, the brake linings are pressed against the brake disc, and the movement of the wheel is stopped.

3.5

Electric drive system

The vehicle is driven by muscle power applied to the chain drive. The force which is applied by pedalling in the direction of travel, drives the front chain wheel. The chain transmits the force onto the rear chain wheel and then onto the rear wheel.

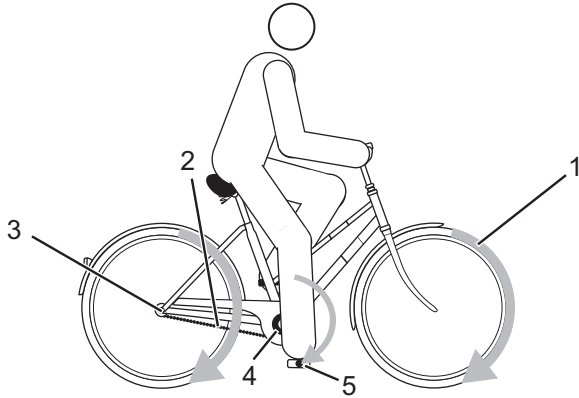

Figure 9:

Diagram of drive system

- 1 Direction of travel
- 2 Chain
- 3 Rear chain wheel
- 4 Front chain wheel
- 5 Pedal

The vehicle also has an integrated, electric drive system. The electric drive system is made up of 8 components:



Figure 10:

Diagram of electric drive system

- 1 *Headlight*
 - 2 *Horn*
 - 3 *Display*
 - 4 *Command console*
 - 5 *Rear and brake light*
 - 6 *Motor*
 - 7 *Battery*
- a charger which is designed for this battery.

As soon as the required muscle power from the rider pedalling passes a certain level, the motor is activated gently and assists the pedalling motion of the rider. The motor force is determined by the set level of assistance. The motor switches off automatically as soon as the rider no longer pedals, the temperature is outside the permitted range, there is an overload, or the shut-off speed of 45 km/h has been reached.

A push assist system can be activated. The push assist continues to drive the vehicle as long as the rider pushes the plus button on the *handlebars*. The speed can be a maximum of 6 km/h in this case. The drive stops when the plus button is released.

3.5.1

Headlight

The running light is automatically switched on when the drive is turned on and cannot be switched off.

The headlight features a sensor, which allows the headlight to distinguish between DAYLIGHT and DARKNESS mode.

DAYLIGHT mode

The complete lamp unit is lit. The running light is lit in dimmed mode and the extra LEDs for daytime use are activated.

DARKNESS mode

The running light is lit at full power.

3.5.2

Horn

The vehicle features an electric horn to signal a warning.

3.5.3

Display

The display controls the drive system and shows the journey data.

The vehicle's battery powers the display when the display is inserted in the mount, a sufficiently charged battery is used on the vehicle and the drive system is switched on.

Internal lithium ion battery	3.7 V, 240 mAh
Storage temperature	5 °C - 25 °C
Charging ambient temperature	10 °C - 30 °C

Table 8:

Display technical data

The *display* has a USB port.



Figure 11:

Display details with its indicator (1) and USB port (2)

3.5.3.1 USB port

There is a USB port underneath the rubber cover on the lower edge of the *display*.

Charge voltage	5 V
Charging current	max. 500 mA

Table 9: USB port technical data

3.5.3.2 Screen displays

The *display* has ten screen displays:

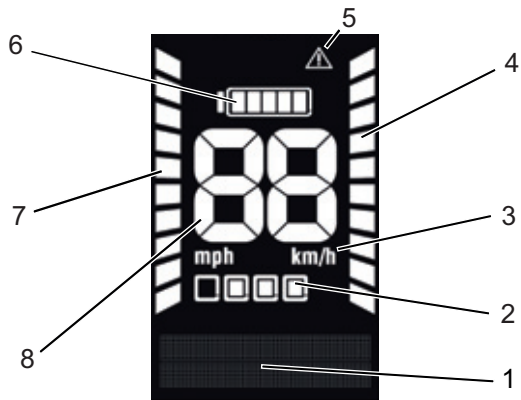

Figure 12: Overview of the screen displays

Use	
1	Function display
2	Level of assistance screen
3	Unit of measure for speed
4	Display of rider's power output
5	Warning symbol
6	Battery status screen
7	Motor power output screen
8	Current speed

Table 10: Overview of the screen display

Level of assistance

The higher the selected level for assistance, the more the drive system assists the rider when pedalling. The following levels of assistance are available.





Screen	Level of assistance
	off
	1
	2
	3
	4

Table 11: Levels of assistance screen

Current speed

In the system settings, you can select whether the speed is displayed in kilometres or miles.

Function screen

The function display shows three different items of information:

- Journey information,
- System settings and data, and
- System messages.

Journey information

Depending on the type of vehicle, the function display may show up to seven journey information items. The displayed journey information can be switched.

Screen	Function
CLOCK	Current time, displayed in hh:mm
TRIP DISTANCE	Distance travelled since the last reset, displayed in kilometres or miles
TRIP KCAL	Calories burned since the last reset, displayed in calories
TRIP TIME	Time elapsed since the last reset, displayed in hh:mm
AVG. SPEED	Average speed since the last reset, displayed in kilometres per hour or miles per hour
MAX. SPEED	Maximum speed travelled since the last reset, displayed in kilometres per hour or miles per hour
TOTAL DISTANCE	Total distance travelled, displayed in kilometres or miles
TOTAL TIME	Travelled time, displayed in hh:mm

Table 12:

Journey information**System settings and data**

In order to see the system settings, the rider has to call up the system settings. The rider can change the values of the system settings.

Screen	Function
RESET TRIP	Reset all TRIP data
RESET ALL	Reset all data
TIME FORMAT	Displays the time either in the 24-hour or 12-hour format.
UNITS OF MEASURE	The units of measure are switched between kilometres and miles.

Table 13:

Changeable system settings

System message

The drive system monitors itself continuously and if an error is detected, it is indicated by a system message. The system may switch off automatically depending on the type of error. There is a table of system messages in the Appendix.

3.5.4

Command console

The command console has five buttons.

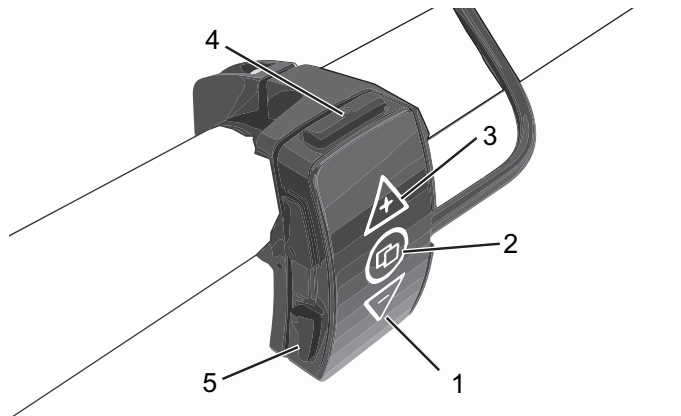

Figure 13:

Overview of the command console



	Symbol	Surname
1	–	Minus button
2		Info button
3	+	Plus button
4		On-Off button
6		Push assist button

Table 14:

Overview of the command console

3.5.5 Rear and brake light

The rear light is automatically switched on when the drive is turned on and cannot be switched off.

The brake light automatically indicates braking if a brake lever is pulled.

3.5.6 Battery

The lithium ion battery has an internal electronic protection circuit. It is matched to the charger and the vehicle. The battery temperature is monitored at all times. The battery is safeguarded against deep discharge, overcharging, overheating and short circuit. In case of a risk the battery is switched off automatically by a protective circuit. The battery also switches to sleep mode for self-protection when not used for a longer period.

The service life of the battery can be extended if it is well cared for and, above all, stored at the correct temperatures. Even if the battery is cared for properly, the charge status of the battery reduces as it ages. If the operating time is severely shortened after charging, this is a sign that the battery is spent.

Transportation temperature	5 °C - 25 °C
Ideal transportation temperature	10 °C - 15 °C
Storage temperature	5 °C - 25 °C
Ideal storage temperature	10 °C - 15 °C
Charging ambient temperature	10 °C - 30 °C

Table 15: Battery technical data

The vehicle has an integrated battery.

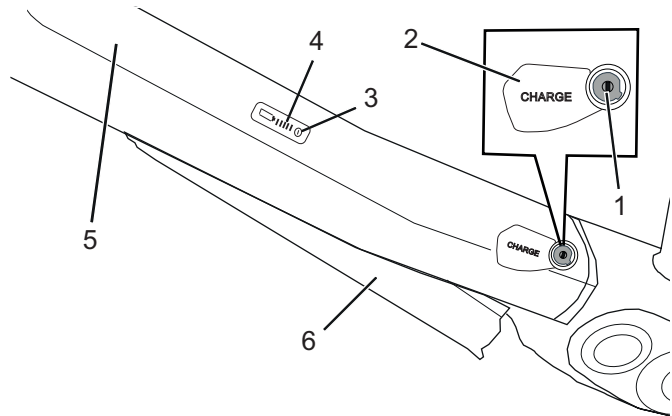

Figure 14:

Integrated battery details

- 1 Battery lock
- 2 Port for charger plug
- 3 On-Off button (battery)
- 4 Operating and charge status indicator
- 5 Top of down tube
- 6 Battery

3.5.6.1

Operating and charge status indicator

The five green LEDs on the operating and charge status indicator indicate the battery charge status when the battery is switched on. Each LED represents 20% of the charge status. The charge status of the activated battery is also shown on the *display*.

If the charge status of the battery is below 5%, all the LEDs of the operating and charge status indicator go out. However, the charge status is still shown on the *display*.

4 Technical data

4.1 Vehicle

Weight	25.2 kg
Maximum gross load weight	115.0 kg
Transportation temperature	5 °C - 25 °C
Ideal transportation temperature	10 °C - 15 °C
Storage temperature	5 °C - 25 °C
Ideal storage temperature	10 °C - 15 °C
Operation temperature	5 °C - 35 °C
Working environment temperature	15 °C - 25 °C
Charging temperature	10 °C - 30 °C
Power output/system	250 W (0.25 kW)
Shut-off speed	45 km/h

Table 16: Vehicle technical data

4.2 Battery

Transportation temperature	5 °C - 25 °C
Ideal transportation temperature	10 °C - 15 °C
Storage temperature	5 °C - 25 °C
Ideal storage temperature	10 °C - 15 °C
Charging ambient temperature	10 °C - 30 °C

Table 17: Battery technical data

4.3 Display

Internal lithium ion battery	3.7 V, 240 mAh
Storage temperature	5 °C - 25 °C
Charging ambient temperature	10 °C - 30 °C

Table 18: Display technical data

4.4 Emissions

A-weighted emission sound pressure level	< 70 dB(A)
Total vibration level for the hands and arms	< 2.5 m/s ²
Highest effective value of weighted acceleration for the entire body	< 0.5 m/s ²

Table 19: Emissions from the vehicle*
 *The safety requirements as per Electromagnetic Compatibility Directive 2014/30/EU have been met. The vehicle and charger can be used in residential areas without restriction.

4.5 USB port

Charge voltage	5 V
Charging current	max. 500 mA

Table 20: USB port technical data

4.6

Fork

Yari RC, Solo Air

Part	Tool or measurement
Deflection	100 - 180 mm
Damper	Motion control
Stanchion	
Oil type	5 WT
Oil fill level	100 - 106 mm
Volume	80 ml
Lower fork leg	
Oil type	OW-30
Volume	10 ml
Spring	Solo Air
Stanchion	
Oil type	SRAM Butter
Volume	Lubricate air piston
Lower fork leg	
Oil type	OW-30
Volume	10 ml

Table 21:

Oil volume and lubricant for the fork

Deflection	150 mm/160 mm	170 mm/180 mm
< 63 kg < 140 lbs	55 - 65 psi	45 - 55 psi
63 - 72 kg 140 - 160 lbs	65 - 75 ps	55 - 65 psi
72 - 81 kg 160 - 180 lbs	75 - 85 psi	65 - 75 ps
81 - 90 kg 180 - 200 lbs	85 - 95 psi	75 - 85 psi
90 - 99 kg 200 - 220 lbs	95 - 105 psi	85 - 95 psi
< 99 kg 220 lbs	+ 105 psi	+ 95 psi
MAX, PSI	148 psi	148 psi

Table 22: Fork filling pressure table

Deflection	TOKENS EX WORKS	MAXIMUM TOKENS
120		47
130		36
140		36
150		25
160		25
170		14
180		04

Table 23: Deflection, Bottomless Tokens

Rider's weight	Full turns in an anti-clockwise direction
< 54 kg	2.0 +
54 - 68 kg	1.5 - 2.0
68 - 82 kg	1.0 - 1.5
82 - 95 kg	0.5 - 1.0
< 95 kg	0.0 - 0.5

Table 24: Floodgate table

4.7

Brake

Part	Info or measurement
Brake disc	Magura, type 9.P Performance Metal ceramic coating
Brake lining wear limit	1.8 mm
Brake disc	Magura, Storm HC, Ø 203 mm
Brake disc wear limit	1.8 mm
Grip Ø brake handle	22 mm
Distance from base	74 mm
Brake cable Ø	5 mm

Table 25: Brake technical data

4.8 Tyres

Part	Info or measurement
Size designation	ETRON 70-584 [27.5 x 2.8 inch]
Tyre pressure*	120 - 260 kPa (1.20 - 2.60 bar)

Table 26: Tyres technical data

*After changing a tyre, you must consult the tyre markings for the permitted tyre pressures and make sure that they are observed.

4.9 Headlight

Comus International, F-170 EB

Part	Info or measurement
Light output	70 lx
Power rating	3 W

Table 27: Headlight technical data

4.10

Tightening torque

Part	Tool	Torque
Axle nuts		35 Nm - 40 Nm
Handlebars clamping screw*		5 Nm - 7 Nm
Fork		
Handlebars clamping screw maximum tightening torque*		5 Nm - 7 Nm
Air suspension guide rod nut	8 mm hex attachment and 12 mm socket nut	3.0 - 3.6 Nm
Bleeder screw – rebound damper sealing head (Charger 2 Damper™ – Lyrik™)	T10 TORX® Socket key attachment	1.1 - 2.3 Nm
Lower screws	5 mm hex attachment	7.3 Nm
Bottomless Tokens™	8 mm hex wrench and 24 mm spanner or RockShox Top cap/cassette tool (or standard cassette tool)	3.4 - 4.5 Nm
Compression damper in cartridge barrel (Charger Damper™ RC – Yari™)	24 mm socket nut or RockShox top cap/cassette tool (or standard cassette tool)	9 Nm
Rebound damper piston (Motion Control™ RC – Yari™)	15 mm spanner head	2.4 - 4.0 Nm
Attachment screw for compression adjustment ring and remote control ring (Charger Damper RC – Yari)	2 mm hex attachment	1.35 Nm
Attachment screw for compression adjustment ring and remote control ring (Motion Control – Yari)	2.5 mm hex attachment	1.2 Nm

Table 28: Tightening torque values

Locking screw for rebound adjustment ring	2.5 mm hex attachment	0.85 Nm
Locking screw for remote control stop ring	2 mm hex attachment	0.25 - 0.6 Nm
Caps	24 mm socket nut or RockShox top cap/cassette tool (or standard cassette tool)	28 Nm

Rear frame damper		
--------------------------	--	--

Air chamber in guide rod eye	13 mm spanner head	4.50 Nm
-------------------------------------	--------------------	---------

Piston nut	12 mm socket nut	4.50 Nm
-------------------	------------------	---------

Sealing head–air piston assembly group	17 mm spanner head	28 Nm
---	--------------------	-------

End cap locking screw	2 mm hex wrench	0.90 Nm
------------------------------	-----------------	---------

Pull ring cover plate	T25 TORX® wrench	0.750 Nm
------------------------------	------------------	----------

Pull clamping screw	2 mm hex wrench	0.80 Nm
----------------------------	-----------------	---------

Brake		
--------------	--	--

Lower clamping screw		4 Nm
-----------------------------	--	------

Gland nut	T25 TORX® wrench	4 Nm
------------------	------------------	------

Brake lining securing screw		max. 2.5 Nm
------------------------------------	--	-------------

Fill opening		max. 4 Nm
---------------------	--	-----------

ETB screw		max. 0.5 Nm
------------------	--	-------------

Lock screw	8 mm spanner head	4 Nm
-------------------	-------------------	------

Adapter screw	T25 TORX® wrench	6 Nm
----------------------	------------------	------

Brake disc screw	T25 TORX® wrench	4 Nm
-------------------------	------------------	------

Table 28: Tightening torque values

Brake caliper attachment screw

T25 TORX® wrench

6 Nm

Pedals		
---------------	--	--

Crank screw

Size 15 open-ended spanner

34 Nm

Table 28:

Tightening torque values

5 Transportation, storage and assembly

5.1 Transportation



Crash caused by unintentional activation

There is a risk of injury if the drive system is activated unintentionally.

- ▶ Remove the battery before the vehicle is transported.



Risk of fire and explosion due to high temperatures

Excessively high temperatures damage the batteries. The batteries may self-ignite and explode.

- ▶ Never expose the battery to sustained direct sunlight.



Oil leak if no transport securing device

The brake securing device prevents the brakes from being applied accidentally during transport. This could cause irreparable damage to the brake system or an oil leak, which will harm the environment.

- ▶ Never pull the brake lever when the wheel has been dismantled.
- ▶ Always use the transport securing system when transporting dismantled wheels.



NOTICE

If the vehicle is lying flat, oil and grease may leak from the vehicle.

If the shipping box with a vehicle is lying flat or on one end, it does not provide the *frame* and the wheels with adequate protection from damage.

- ▶ Transport the vehicle in an upright position only.
-

NOTICE

Vehicle rack systems which secure the vehicle by its *handlebars* or *frame* in an upside-down position exert inadmissible forces on the components during transportation. This can cause the supporting parts to break.

▶ Never use vehicle rack systems which secure the vehicle by its *handlebars* or *frame* in an upside-down position.

▶ Take into account the ready-to-use vehicle's weight when transporting it.

▶ Remove the *display* and the battery before transporting the vehicle.

▶ Protect the electrical components and connections on the vehicle from the elements with suitable protective covers.

▶ Remove accessories such as drinking bottles before transporting the vehicle.

▶ You must use a suitable vehicle rack system when transporting by car.



The ZEG specialist dealer will advise you on how to select a suitable rack system properly and how to use it safely.

▶ Transport the vehicle in a dry, clean place where it is protected from direct sunlight.



When shipping the vehicle, we recommend that you have it partially dismantled and packaged properly by the ZEG specialist dealer.

5.1.1

Using the transport securing system

- ▶ Insert two transport securing devices between the brake linings in each calliper.
- ⇒ The transport securing device is squeezed between the two linings.

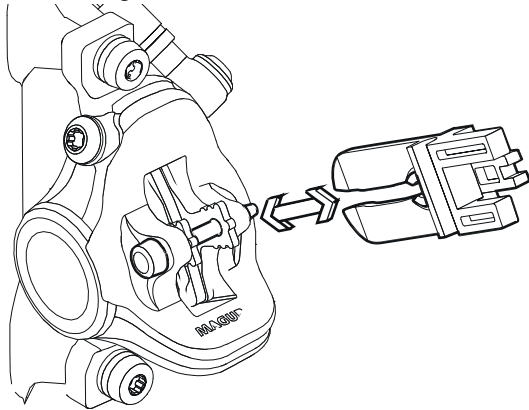

Figure 15:

Fastening the transport securing device

5.2

Storing



CAUTION

Risk of fire and explosion due to high temperatures

Excessively high temperatures damage the battery. The battery may self-ignite and explode.

- ▶ Never expose the battery to sustained direct sunlight.

NOTICE

If the vehicle is lying flat, oil and grease may leak from the vehicle.

If the shipping box with a vehicle is lying flat or on one end, it does not provide the *frame* and the wheels with adequate protection from damage.

- ▶ Store the vehicle in an upright position.

- ✓ In the case of a vehicle with a hydraulic seat post, fix only the lower seat post or the frame into a fitting stand to prevent damage to the upper seat post and the seat post lever.
- ✓ Never place a vehicle with a hydraulic seat post upside down on the floor; otherwise you, will damage the seat post lever.
- ✓ Store the vehicle, battery and charger in a dry and clean place.

Storage temperature	5 °C - 25 °C
Ideal storage temperature	10 °C - 15 °C

Table 29:

Storage temperature for the battery, vehicle and charger

5.2.1

Break in operation

NOTICE

The battery discharges when it is not used. This can cause damage to the battery.

- ▶ The battery has to be recharged every 8 weeks.

NOTICE

The battery may become damaged if it is connected permanently to the charger.

- ▶ Do not connect the battery to the charger permanently.

NOTICE

The internal battery in the display discharges when it is not used. This can cause it to be irreparably damaged.

- ▶ Charge the internal battery in the display every 3 months for at least 1 hour.

If the vehicle is to be removed from service for longer than four weeks, e.g. in winter, you need to prepare for a break in operation.

5.2.1.1

Preparing a break in operation

- ✓ Remove the battery from the vehicle.
- ✓ Charge the battery to around 60% (three to four LEDs of the charge status indicator light up).
- ✓ The vehicle needs to be cleaned with a damp cloth and preserved with wax spray. Never wax the friction surfaces of the brake.
- ✓ Before longer periods without use, it is recommendable for the ZEG specialist dealer to carry out servicing, basic cleaning and to apply preservative agent.

5.2.1.2

Carrying out break in operation

- ▶ Store the vehicle, battery and charger in a dry and clean environment.
- ▶ Charge the internal battery in the display every 3 months for at least 1 hour.
- ▶ Check the charge status of the battery after 8 weeks. If only one LED of the charge status indicator lights up, recharge the battery to around 60%.

5.3

Assembly



Crushing caused by unintentional activation

There is a risk of injury if the drive system is activated unintentionally.

- ▶ Remove the battery if the battery is not absolutely necessary for assembly.



- ✓ Assemble the vehicle in a clean, dry environment.
- ✓ The working environment temperature should be between 15 °C and 25 °C.

Working environment temperature 15 °C - 25 °C

Table 30:

Working environment temperature

- ✓ If a fitting stand is used, it must be approved for a maximum weight of 30 kg.
- ✓ We recommend that you always remove the battery from the vehicle to reduce weight while the fitting stand is used.
- ✓ Universal tools, a torque spanner with an operating range of 5 Nm to 40 Nm and the special tools, as recommended by ZEG Zweirad-Einkaufs-Genossenschaft eG, must be available for use.

5.3.1

Unpacking



Hand injuries caused by cardboard packaging

The shipping carton is closed with metal staples. There is a risk of puncture wounds and cuts when unpacking and crushing the packaging.

- ▶ Wear suitable hand protection.
- ▶ Remove the metal staples with pliers before the shipping carton is opened.

The packaging material consists mainly of cardboard and plastic film.

- ▶ The packaging has to be disposed of in accordance with the regulations of the authorities.

5.3.2

Scope of delivery

The vehicle was completely assembled in the factory for test purposes and then dismantled for transportation.

The scope of delivery includes:

- the vehicle, 98% pre-assembled
- the front wheel
- the pedals
- the charger
- the battery.

5.3.3

Commissioning**Fire and explosion caused by incorrect charger**

Batteries which are charged with an unsuitable charger, may become internally damaged. This may result in fire or an explosion.

- ▶ Only ever use the battery with the supplied charger.
- ▶ Mark the supplied charger and these operating instructions clearly to prevent mix-ups – with the vehicle *frame number* or *type number*, for example .

Only trained technical staff should perform initial commissioning of the vehicle since this requires special tools and specialist knowledge.

Experience has shown that a vehicle which has not yet been sold is automatically handed to end users as soon as it appears ready to ride.

- ▶ For this reason, every vehicle must be prepared, so that it is fully ready for use immediately after being assembled.
- ▶ Staff should work through the initial commissioning check list to prepare the vehicle, so that it is ready to ride.

5.3.3.1

Initial commissioning check list

- | | |
|--------------------------|--|
| <input type="checkbox"/> | Check battery [see Section 5.3.3.2, page 55]. |
| <input type="checkbox"/> | The battery is supplied partially charged. In order to guarantee full power, charge the battery fully. |
| <input type="checkbox"/> | Mount the wheels, quick release and pedals. |
| <input type="checkbox"/> | Adjust the quick release clamping force if necessary. |
| <input type="checkbox"/> | Clean brake discs thoroughly with brake cleaner or spirit. |
| <input type="checkbox"/> | Move the handlebars and saddle into the working position. |
| <input type="checkbox"/> | Check all the components to make sure that they are firmly in place. Check all the settings and the tightening torque on the axle nuts. |
| <input type="checkbox"/> | <p>Check the entire cable harness to make sure that it is routed properly:</p> <ul style="list-style-type: none"> • You must prevent the cable harness from coming into contact with moving parts. • The cable routes must be smooth and free from sharp edges. • Moving parts must not apply any pressure or tension to the cable harness. |
| <input type="checkbox"/> | Check the drive system, the light equipment and the brakes to make sure that they are fully functional and effective. |
| <input type="checkbox"/> | Adjust the headlight. |
| <input type="checkbox"/> | Set the drive system has to the national language and the appropriate system of measurement. |
| <input type="checkbox"/> | Check the software version of the drive system and update it as necessary. |
| <input type="checkbox"/> | Take a test drive to check the brake system, gear shift and the electric drive system. |

5.3.3.2

Checking the battery

The battery has to be checked before it is charged for the first time.

- ▶ Press the *On-Off button (battery)*.
- ⇒ If none of the LEDs on the operating and charge status indicator light up, the battery may be damaged.
- ⇒ If at least one of the LEDs of the operating and charge status indicator lights up, but not all of them, the battery can be charged.
- ▶ Insert the battery into the vehicle once it has been charged.
- ⇒ Verify that the battery is a BMZ battery.

5.3.3.3

Sell vehicle

- ▶ Adjust the vehicle to the rider.
- ▶ Set the *stand* and the *shifter*, and show the purchaser the settings.
- ▶ Instruct the user or rider on how to use all the vehicle's functions.

6 Adjust vehicle to rider



The ZEG specialist dealer checks all default settings and adjusts the *saddle*, *handlebars*, *fork* and the *rear frame damper* to the rider when the sale is made.

6.1 Saddle

6.1.1 Determining the seat height



Crash caused by an excessively high seat post setting

A *seat post* with is set too high will cause the *seat post* or the *frame* to break. This will result in a crash and injuries.

- ▶ Do not pull the seat post out of the frame beyond the minimum insertion depth marking.

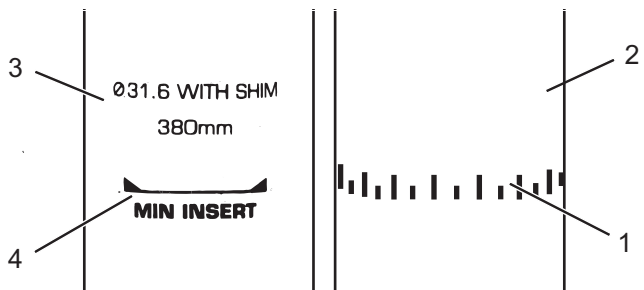

Figure 16:

Detail view of seat posts for seat post I (2) and seat post II (3), examples of the minimum insertion depth mark with minimum mark (4) and bar marking (1)

From an ergonomic point of view, the seat height should be set so that the heel touches the lowest point of the pedal when the leg is outstretched.

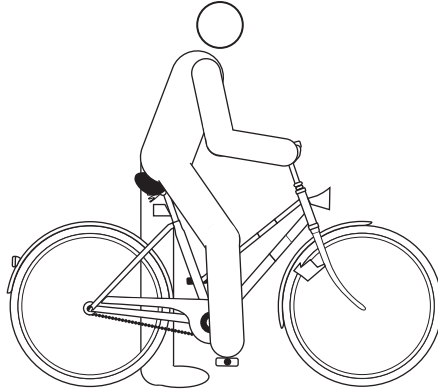

Figure 17: Determining the saddle height

6.1.2 Clamping the seat post



The ZEG specialist dealer demonstrates the function of the quick release to the rider or user.



Figure 18: Seat post (2) quick release in the clamping lever end position on the seat post (1) and its knurled nut (3)

- ✓ Only clamp the *seat post* when the vehicle is stationary.

The *seat post clamping lever* is not marked with any lettering. You can tell whether it is open or closed from its shape.

- To close it, push the *seat post clamping lever* as far as it will go into the *seat post*.
- To open it, pull the *seat post clamping lever* away from the *seat post*.

▶ Check the *clamping force of the quick releases*.

6.1.3



Adjusting the sitting position and saddle tilt

Special tools are required to adjust the seat length and the saddle tilt. The ZEG specialist dealer adjusts the saddle setting to the rider.

6.2



Setting the handlebars

- ✓ The handlebars setting must only be made while the vehicle is stationary.
- ▶ Unfasten clamping screws, adjust stem and clamp it into position applying the maximum tightening torque for the clamping screws.

Maximum tightening torque for the clamping screws of the handlebars*

5 Nm - 7 Nm

*if there is no other data on the component

Table 31:

Handlebars clamping screw maximum tightening torque

6.3 Brake lever

6.3.1 Adjusting the pressure point



Brake failure due to incorrect setting

If the pressure point is set with brakes where the brake lining and brake disc have reached their wear limit, the brakes may fail and cause an accident with injury.

- ▶ Before you set the pressure point, ensure that the brake lining and brake disc have not reached their wear limit.

The pressure point setting is adjusted using the twist knob.

- ▶ Turn the twist knob towards the plus (+) symbol.
 - ⇒ The brake lever moves closer to the handlebar grip. Re-adjust the grip distance as necessary.
 - ⇒ The lever pressure point activates sooner.

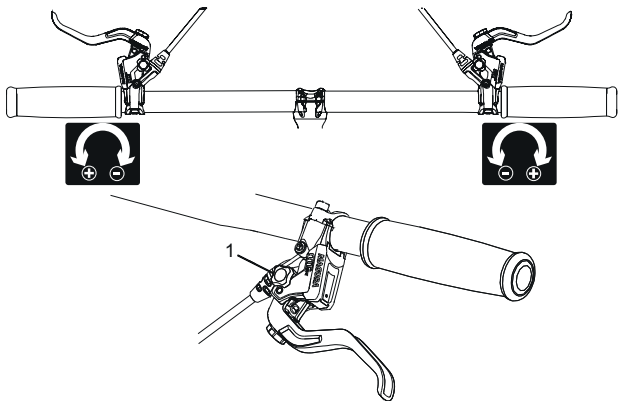

Figure 19: Using the twist knob (1) to adjust the pressure point

6.3.2

Setting grip distance**Brake failure due to incorrect setting**

If the brake lever is positioned too close to the handlebar grip, the full braking force cannot be applied. The brakes will fail, causing a crash and injuries.

- ▶ Never position the brake lever less than the minimum distance of 20 mm from the handlebar grip.

The brake lever position (grip distance) can be adjusted to the rider's requirements. Use a T25 TORX® wrench to turn the setting screw to adjust the grip distance.

- ▶ Turn the setting screw in the minus (-) direction.
⇒ The brake lever moves closer to the handlebar grip.
- ▶ Turn the setting screw in the plus (+) direction.
⇒ The brake lever moves away from the handlebar grip.

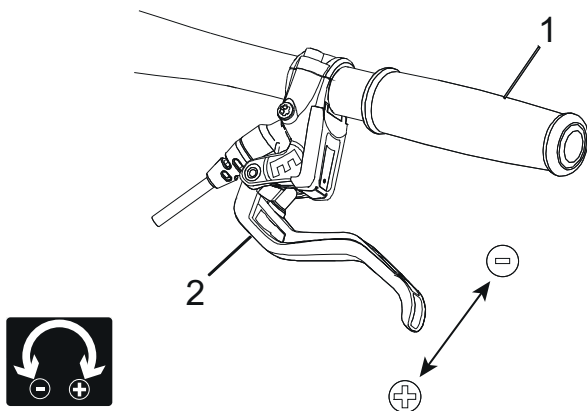

Figure 20:

Using the setting screw (2) to adjust the distance from the brake lever to the handlebar grip (1)

6.4

Suspension and damping

The adjustment shown here represents a basic setting. The rider should change the basic setting to suit the surface and his/her preferences.

- ▶ It is advisable to make a note of the basic setting. This way, it can be used as the starting point for subsequent, optimised settings and to safeguard against unintentional changes.

6.4.1

Adjusting the suspension

NOTICE

Riding without filling pressure will destroy the wheel suspension, the frame and the air suspension elements.

- ▶ Never ride without filling pressure in the air suspension elements.
-

A normal air pump cannot build up the required pressure sufficiently.

- ▶ Always use a special high-pressure damper pump to adjust the filling pressure.
-

6.4.1.1**Front wheel**

The air chamber valve can be used to adjust the fork suspension to the rider's weight and driving style.

Adjusting tyre pressure

The tyre pressure determines the force required to press the fork together. If the tyre pressure is reduced, the fork slackens more and rebounds less.

- ✓ Only adjust the tyre pressure when the vehicle is stationary.
- ▶ The air valve is located under a screw cap on the head of the left shock absorber. Unscrew and remove the screw cap.
- ▶ Adjust the air pressure as an initial value using a high-pressure damper pump and based on the tyre pressure table and the rider's weight.

Deflection	150 mm/160 mm	170 mm/180 mm
< 63 kg < 140 lbs	55 - 65 psi	45 - 55 psi
63 - 72 kg 140 - 160 lbs	65 - 75 ps	55 - 65 psi
72 - 81 kg 160 - 180 lbs	75 - 85 psi	65 - 75 ps
81 - 90 kg 180 - 200 lbs	85 - 95 psi	75 - 85 psi
90 - 99 kg 200 - 220 lbs	95 - 105 psi	85 - 95 psi
< 99 kg 220 lbs	+ 105 psi	+ 95 psi
MAX, PSI	148 psi	148 psi

Table 32:**Air fork tyre pressure table**

Adjusting sag

Sag refers to the fork's deflection under the rider's weight. If the sag is set correctly, the front wheel can maintain better contact with the ground as you ride over rough terrain. If the positive tyre pressure increases, the sag also increases. The fork lock must be open.

- ✓ The fork sag is displayed on the deflection indicator on the upper fork tube. The indicator must rest against the top seal.
- ▶ The rider sits on the vehicle wearing their normal riding outfit and puts pressure on the handlebars.
- ▶ The rider dismounts from the vehicle again.
- ▶ Read distance between the seal and the deflection indicator. This distance corresponds to the fork's sag.
- ⇒ Optimum sag is about 20% of the maximum deflection.
Example for a maximum deflection of 160 mm:
 $0.2 \times 160 \text{ mm} = 32 \text{ mm}$ (the fork's sag)
- ▶ If the sag is not set to an optimum level, it can be optimised by adjusting the positive tyre pressure.

Setting fork lock

You can finely adjust the point where the fork lock is deactivated, so that the fork responds to impact caused by uneven surfaces or obstacles. The floodgate adjuster is used to adjust this point. The floodgate adjuster is yellow and is positioned in the middle of the fork lock.

The floodgate adjuster adapts suspension behaviour during medium impacts and fork movement (bobbing up and down) which is caused by resistance to the rider. Bobbing is prevented if settings are correct without affecting suspension motion on challenging terrain.

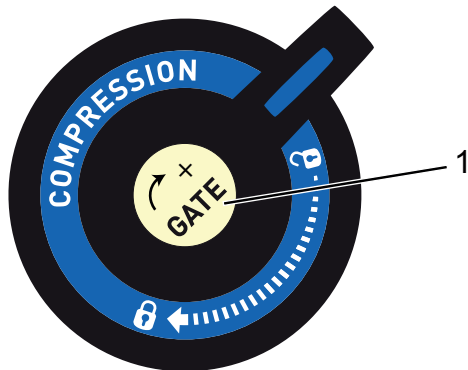

Figure 21:

Fork lock with floodgate adjuster (1)

- ✓ Only adjust the fork lock when the vehicle is stationary.
- ▶ Locking the fork lock.
- ▶ Turn the floodgate adjuster clockwise to the maximum setting.

- Use the floodgate table to adjust to the optimal floodgate setting by turning anti-clockwise based on the rider's weight.

Rider's weight	Full turns in an anti-clockwise direction
< 54 kg	2.0 +
54 - 68 kg	1.5 - 2.0
68 - 82 kg	1.0 - 1.5
82 - 95 kg	0.5 - 1.0
< 95 kg	0.0 - 0.5

Table 33: Floodgate table

6.4.1.2 Rear wheel

Adjusting tyre pressure

The tyre pressure determines the force required to press the rear frame damper together. If the tyre pressure is reduced, the fork slackens more and rebounds less.

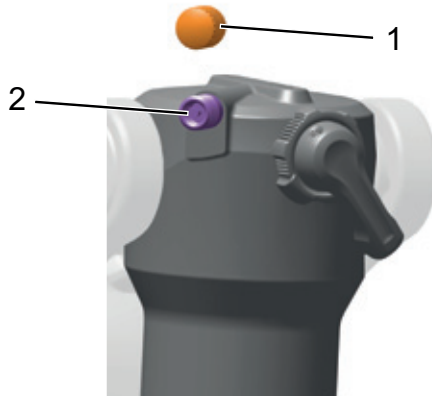

Figure 22: Rear frame damper with air valve cap (1) and valve (2)

- ✓ Only adjust the tyre pressure when the vehicle is stationary.
 - ▶ Remove the valve cap.
 - ▶ Use the high-pressure damper pump to raise the tyre pressure to the required level.
 - ▶ Apply pressure (in psi) to the rear frame damper which matches the rider's overall weight in pounds, including their clothing.
- ⇒ Example:
63 kg = 160 lbs = 160 psi = 11 bar
- ▶ Deflect rear frame damper to compensate the air pressure.
 - ▶ Screw the valve cap back on.

Adjusting sag

Sag refers to the rear frame damper's deflection under the rider's weight. If the sag is set correctly, the front wheel can maintain better contact with the ground as you ride over rough terrain. If the positive tyre pressure increases, the sag also increases. The fork lock must be open.

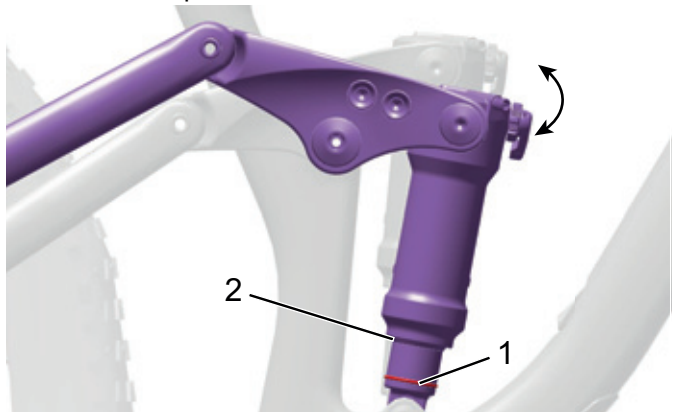

Figure 23:

On deflection (arrow), the O ring (1) is pushed downwards away from the seal (2).

- ✓ There must be two people present to make this setting.
- ▶ The helper stabilises the vehicle.
- ▶ The rider climbs onto the vehicle.
- ▶ Deflect rear frame damper slightly 2-3 times.
- ▶ The helper pushes the O ring against the seal.
- ▶ The rider carefully dismounts from the vehicle without the rear frame damper deflecting.
- ▶ Note down the sag percentage on the O ring ridge.
- ⇒ The optimum rear frame damper sag percentage is 25%.
- ⇒ The sag may be adjusted by $\pm 5\%$, depending on the rider's preference.
- ▶ Adjust the pressure as required and check the sag once more.
 - If the pressure is too high, let out air
 - If the pressure is too low, pump the rear frame damper carefully.
- ▶ Screw the valve cap back on when you have finished pumping.

6.4.2

Setting the rebound damper

The rebound damper determines the speed at which the fork rebounds to full length after deflection. This speed affects the wheel's contact with the ground and thus has an influence on control and efficiency. The rear frame damper should rebound fast enough to sustain traction without producing an erratic or bumpy sensation. If rebound damping is too tight, the damper is unable to rebound fast enough before the next impact.

6.4.2.1

Front wheel

- ▶ The rebound damper is set at the fork base.

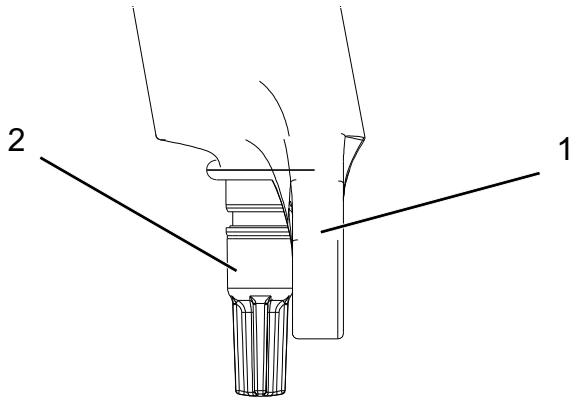
**Figure 24:****Rebound damper setting bolt (2) at the fork base (1)**

- ▶ To do so, turn the rebound damper setting bolt all the way towards the hare symbol or the minus symbol.
- ▶ Stand next to the vehicle. Deflect the fork as far as possible by pushing down the handlebars.
- ▶ Release the handlebars abruptly.
- ⇒ The ideal setting for the rebound damper has been achieved when the wheel maintains contact with the floor when springing back.
- ▶ If the wheel loses contact with the floor, turn back in small steps towards the tortoise symbol or plus symbol.

Rear wheel

The rebound damper for the rear wheel is located in the rear frame damper.



Figure 25:

Setting the rebound damper strength on the rear frame damper setting wheel (1)

- ▶ Turn the setting wheel to the middle position.
- ▶ Ride the vehicle over a small obstacle.
- ⇒ The ideal setting for the rebound damper has been achieved when the rebound movement of the rear wheel feels comparable to that of the front wheel.
- ▶ If the rear wheel bounces back much more quickly or slowly than the front wheel, change the setting by turning the setting wheel.
- Turn the setting wheel in an anti-clockwise direction to increase the rebound speed.
- Turn the setting wheel in a clockwise direction to decrease the rebound speed.

6.4.3 Setting the compression damper

The compression damper controls the speed at which the rear frame damper deflects during slow impact, such as smaller impacts or when the rider goes round a corner or shifts their weight. The damper improves control and efficiency.

If the compression damper is set too high, the suspension is too hard during impacts.

6.4.3.1 Front wheel

- Use the locking lever to adjust to the optimum basic setting by picking any position between the fork lock's open and locked position.

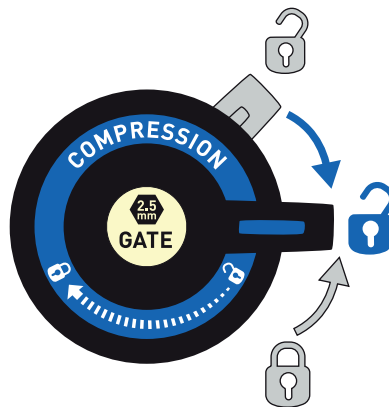

Figure 26: Setting the compression damper

6.4.3.2

Rear wheel

- ▶ The lever is used to set the compression damper.
- Turn the setting wheel in a clockwise direction (+) to decrease the deflection speed.
- ▶ Turn the setting wheel in an anti-clockwise direction (-) to increase the deflection speed.

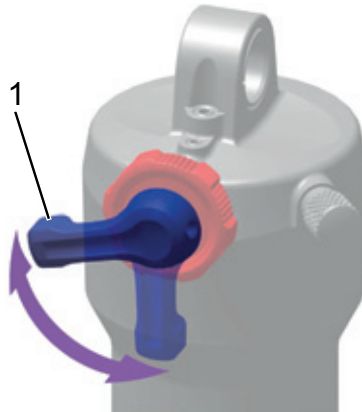

Figure 27:

Setting the compression damper strength using the rear frame damper setting lever (1)

6.5

Retracting brake linings

New brake linings take time to break in and adjust to their final braking force.

- ▶ Accelerate vehicle to about 30 km/h.
 - ▶ Brake vehicle until it comes to a halt
 - ▶ Repeat process 30–50 times.
- ⇒ The brake linings and brake discs are now broken in and provide optimal braking power.

7

Operation



Crash caused by loose clothing

Laces, scarves and other loose items may become entangled in the spokes on the *wheels* and the *chain drive*. Such damage may cause you to fall from the vehicle and injure yourself.

- ▶ Wear sturdy footwear and close-fitting clothing.
-



Crash caused by soiling

Heavy soiling can impair the functions of the vehicle, for example, the function of the brakes. Such damage may cause you to fall from the vehicle and injure yourself.

- ▶ Remove coarse soiling before riding.
-



Crash caused by poor road conditions

Loose objects, for example, branches and twigs, may become caught in the wheels and cause a crash.

- ▶ Be aware of the road conditions.
 - ▶ Ride slowly and brake in good time.
-

NOTICE

When riding downhill, high speeds may be reached. The vehicle is only engineered for exceeding a speed of 45 km/h briefly. In particular the *tyres* can fail if exposed to a continuous load.

- ▶ Decelerate the vehicle with the brakes if higher speeds than 45 km/h are reached.
-

NOTICE

Heat or direct sunlight can cause the *tyre pressure* to increase above the permitted maximum pressure. This can destroy the *tyres*.

- ▶ Never park the vehicle in the sun.
- ▶ On hot days, regularly check the *tyre pressure* and adjust it as necessary.

You can be ride the vehicle within a temperature range between 5 °C and 35 °C. The effectiveness of the drive system is restricted outside of this temperature range.

Operation temperature

5 °C - 35 °C

As a result of the open construction, penetration from moisture at cold temperatures may impair individual vehicle functions.

- ▶ Always keep the vehicle dry and free from frost.
- ▶ If the vehicle is to be operated at temperatures below 3 °C, the ZEG specialist dealer must first prepare the vehicle for winter use.



Off-road riding subjects the joints in the arms to severe strain. Take a break from riding every 30 to 90 minutes, depending on the condition of the roads.

7.1

Before each ride**Crash caused by difficult-to-spot damage**

If the vehicle topples over or you have a fall or an accident, there may be difficult-to-spot damage to components such as the brake system, quick releases or *frame*. Such damage may cause you to fall from the vehicle and injure yourself.

- ▶ Take the vehicle out of service and have a ZEG specialist dealer carry out an inspection.

**Crash caused by material fatigue**

A component may suddenly fail in case of material fatigue. Such damage may cause you to fall from the vehicle and injure yourself.

Remove the vehicle from service immediately if there are any signs of material fatigue. Have a ZEG specialist dealer check the situation.

- ▶ Have the ZEG specialist dealer carry out basic cleaning regularly. During basic cleaning, the ZEG specialist dealer checks the vehicle for any signs of material fatigue.
-
- ▶ Check the vehicle before each ride.
 - ⇒ The vehicle must not be used until the cause has been clarified if there are any discrepancies from the *Check list before each ride* or any anomalies of any kind.

7.1.1

Check list before each ride

<input type="checkbox"/>	Check that the vehicle is complete.
<input type="checkbox"/>	Check that the lighting, reflector and brake, for instance, are sufficiently clean.
<input type="checkbox"/>	You must check that the mudguards, the pannier rack and the chain guard are securely installed.
<input type="checkbox"/>	Check that the front and rear wheels run true. This is particularly important if the vehicle has been transported or secured with a lock.
<input type="checkbox"/>	Check the valves and the tyre pressure. Adjust as necessary before each ride.
<input type="checkbox"/>	Check the front and rear wheel brakes to make sure that they are working properly. To do so, operate the brake levers while stationary in order to check whether resistance is generated in the usual brake lever position.
<input type="checkbox"/>	Check that the running light is working.
<input type="checkbox"/>	Check for unusual noises, vibrations, smells, discolouration, deformation, abrasion and wear. This indicates material fatigue.
<input type="checkbox"/>	Be alert to any unusual operating sensations when braking, pedalling or steering.
<input type="checkbox"/>	Check the quick releases to make sure that they are fully closed in their final position.
<input type="checkbox"/>	If the vehicle has a hydraulic rim brake, check whether the locking levers are fully closed in their final positions.

7.2

Using the kickstand

**CAUTION**

Crash caused by a lowered kickstand

The kickstand does not fold up automatically. There is a risk of crashing if riding with the kickstand lowered.

- ▶ Raise the kickstand completely before the ride.
-

NOTICE

The heavy weight of the vehicle may cause the kickstand to sink into soft ground and the vehicle may topple and fall over.

- ▶ The vehicle must be parked on level, firm ground only.
 - ▶ It is particularly important to check stability if the vehicle is equipped with accessories or loaded with luggage.
-

7.2.1

Raising the kickstand

- ▶ Before the ride, raise the kickstand completely with your foot.

7.2.2

Parking the vehicle

- ▶ Before parking, lower the kickstand completely with your foot.
- ▶ Park the vehicle carefully and check that it is stable.

7.3

Battery**Risk of fire and explosion due to faulty battery**

The safety electronics on damaged or faulty batteries may fail. The residual voltage can cause a short circuit. The batteries may self-ignite and explode.

- ▶ Remove batteries with external damage from service immediately and never charge them.
- ▶ If the battery becomes deformed or begins to smoke, keep at a safe distance, disconnect the power supply at the socket, and notify the fire service immediately.
- ▶ Never extinguish damaged batteries with water or allow them to come into contact with water.
- ▶ If a battery is dropped or struck but shows no signs of external damage, remove the battery from service and observe it for at least 24 hours.
- ▶ Faulty batteries are hazardous goods. Dispose of faulty batteries properly and as quickly as possible.
- ▶ Store in a dry place until disposal. Never store in the vicinity of flammable substances.
- ▶ Never open or repair the battery.

**Risk of fire and explosion due to high temperatures**

Excessively high temperatures damage the battery. The battery may self-ignite and explode.

- ▶ Never expose the battery to sustained direct sunlight.



Fire and explosion caused by short circuit

Small metal objects may jumper the electrical connections of the battery. The batteries may self-ignite and explode.

- ▶ Keep paper clips, screws, coins, keys and other small parts away from the battery and do not insert them into the battery.



Chemical burns to the skin and eyes caused by faulty battery

Liquids and vapours may leak from damaged or faulty batteries. They can irritate the airways and cause burns.

- ▶ Avoid contact with leaked liquids.
- ▶ Immediately consult a doctor in case of contact with the eyes or any discomfort.
- ▶ In case of contact with the skin, rinse off immediately with water.
- ▶ Ventilate the room well.



Fire and explosion caused by penetration by water

The battery is only protected from simple spray water. Penetration by water can cause a short circuit. The battery may self-ignite and explode.

- ▶ Never immerse the battery in water.
 - ▶ If there is reason to believe that water may enter into the battery, the battery must be removed from service.
-

NOTICE

If a key is left inserted when transporting the vehicle, or when riding, it may break off or the compartment may open accidentally.

- ▶ Remove the key from the battery lock immediately after use.
- ▶ We recommend that you attach the key to a key ring.

✓ Before the battery is to be removed or inserted, switch off the battery and the drive system.

7.3.1**Removing the battery**

- ▶ Hold the battery in your hand from below.
- ▶ Open the battery lock with the key.
- ⇒ The integrated battery is released and falls out of the down tube into your hand.
- ▶ Pull the integrated battery out of the frame.
- ▶ Remove the key from the lock.

7.3.2**Inserting the battery**

- ▶ Place the battery with the contacts first into the mount above.
- ▶ Push the integrated battery downwards so that it audibly clicks into place.
- ▶ Check the inserted battery to make sure it is firmly in place.

7.3.3

Charging the battery



CAUTION

Fire caused by overheated charger

The charger heats up when charging the battery. In case of insufficient cooling, this can result in fire or burns to the hands.

- ▶ Never use the charger on a highly flammable surface (e.g. paper, carpet etc.).
 - ▶ Never cover the charger during the charging process.
-



CAUTION

Electric shock caused by penetration by water

If water penetrates into the charger, there is a risk of electric shock.

- ▶ Never charge the battery outdoors.
-



CAUTION

Electric shock in case of damage

Damaged chargers, cables and plug connectors increase the risk of electric shock.

- ▶ Check the charger, cable and plug connector before each use. Never use a damaged charger.
-
- ▶ The ambient temperature during the charging process must be within the range from 10 °C to 30 °C.
-

Charging temperature

10 °C - 30 °C

- ✓ The battery can remain on the vehicle or be removed for charging.
- ✓ Interrupting the charging process does not damage the battery.
- ✓ If the vehicle features two batteries, the charging process for both batteries is started via the pannier rack battery.

-
- ▶ Remove the rubber cover from the battery.
 - ▶ Connect the mains plug of the charger to a normal domestic, grounded socket.

Connection data230 V, 50 Hz

- ▶ Connect the charging cable to the battery's charging port.
- ⇒ The charging process starts automatically.
- ⇒ During the charging process the operating and charge status indicator indicates the charge status. When the drive system is switched on, the *display* shows the charging process.
- ⇒ The charging process is complete when the LEDs of the operating and charge status indicator go out.

CAUTION **Risk of fire and explosion caused by damaged batteries.** The safety electronics on damaged or faulty batteries may fail. The residual voltage can cause a short circuit. The batteries may self-ignite and explode. If the battery becomes deformed or begins to smoke, keep at a safe distance, disconnect the power supply at the socket, and notify the fire service immediately. Never extinguish damaged batteries with water or allow them to come into contact with water.

NOTICE If an error occurs during the charging process, a system message is displayed. Remove the charger and the battery from operation immediately and follow the instructions.

7.3.4

Waking the battery

- ✓ When not used for a longer period, the battery switches to sleep mode for self-protection. The LEDs of the operating and charge status indicator do not light up.
- ▶ Press the *On-Off button (battery)*.
- ▶ The battery's operating and charge status indicator indicates the charge status.

7.4 Electric drive system

7.4.1 Switching on the electric drive system



Crash caused by lack of readiness for braking

When it is switched on, the drive system can be activated by the application of force on the pedals. There is a risk of a crash if the drive is activated unintentionally, and the brake is not reached.

- ▶ Never start the electric drive system, or switch it off immediately, if the brake cannot be reached safely and reliably.

-
- ✓ A sufficiently charged battery has been inserted into the vehicle.
 - ✓ The battery is firmly in place. The key has been removed.
 - ▶ Press and hold the **On-Off button (display)** for 2 seconds.
 - ⇒ If the drive system is switched on, the drive is activated as soon as the pedals are moved with sufficient force.

7.4.2 Switching off the electric drive system

- ▶ Press the **On-Off button** (display) once.
- ⇒ The LEDs of the operating and charge status indicator go out.
- ⇒ The system switches off automatically ten minutes after the last command.

7.5 Command console with display

7.5.1 Display

NOTICE

If the rider is not present, the *display* can be used without authorisation, e.g. it may be stolen, the system settings may be changed or journey information may be read.

- ▶ Remove the *display* when the vehicle is parked.

7.5.1.1 Removing the display

- ▶ Turn the *display* 45° anticlockwise.
- ▶ Remove the *display* from above.

7.5.1.2 Attaching the display

- ▶ Place the *display* on the *mount*.
- ▶ Turn the *display* 45° clockwise.

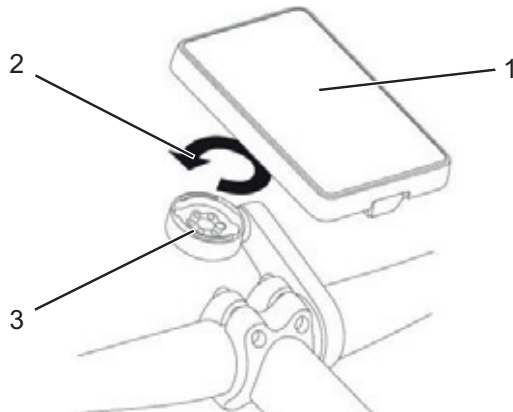

Figure 28: Attach display (1) to the mount (3) by turning it in the direction of rotation indicated by the arrow (2)

7.5.2 Using the USB port

The USB port can be used to operate external devices which can be connected using a standard micro A/ micro B USB 2.0 cable.

- ▶ Open the protective flap on the USB port.
- ▶ Replace the protective flap after using the USB port.

NOTICE Any moisture which enters through the USB port may trigger a short circuit in the *display*. Regularly check the position of the rubber cover on the USB port and adjust it as necessary.

7.5.3 Using the push assist



Fall caused by strong acceleration

If the pedals are pressed with the push assist activated, the vehicle accelerates rapidly. Such damage may cause you to fall from the vehicle and injure yourself.

- ▶ Never mount the vehicle with the push assist activated.

NOTICE

The pedals turn when using the push assist due to the system design.

- ▶ You must steer the vehicle securely with both hands when using push assist.
 - ▶ Allow for enough freedom of movement for the pedals.
 - ▶ Never use a push assist for slow riding.
-

The push assist helps the rider to push the vehicle.
The maximum speed can be 18 km/h here.

- ▶ Press and hold the **push assist button** for longer than three seconds.
- ⇒ The push assist is activated. The *push assist symbol* is displayed.
- ▶ Release the **push assist button** to shut off the push assist.

7.5.4

Selecting the level of assistance

- ▶ Press the **plus button**.
- ⇒ The level of assistance is increased.
- ▶ Press the **minus button**.
- ⇒ The level of assistance is reduced.

7.5.5

Switching journey information

The displayed *journey information* can be changed and partially reset.

- ▶ Press the **info button** repeatedly until the *journey information* is displayed.

7.5.6

Changing the system information

- ▶ Press and hold the **headlight button** for three seconds.
 - ▶ Press the **info button** repeatedly until the *journey information* is displayed.
 - ▶ Change values by pressing the **minus** and **plus buttons**.
 - ▶ When the values are correct, press the **info button** briefly.
 - ▶ Press and hold the **headlight button** for three seconds.
- ⇒ The *journey information* is displayed again.

7.6

Gear shift

The selection of the appropriate gear is a prerequisite for a physically comfortable ride and making sure that the electric drive system functions properly. The ideal pedalling frequency is between 40 and 60 revolutions per minute.

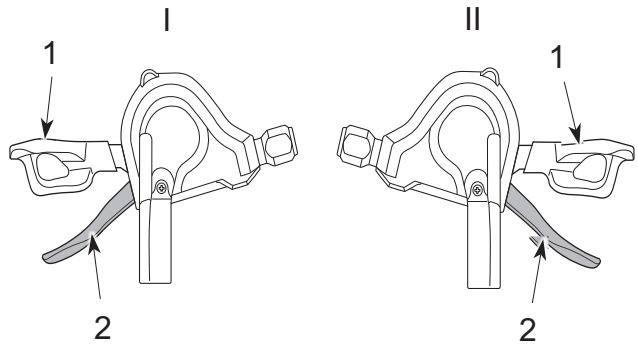

Figure 29: Down shifter (1) and up shifter (2) on the left (I) and right (II) shift

7.6.1

Using the gear shift

- ✓ Keep the pedal crank moving when switching the shifter.
- ▶ Select the appropriate gear with the *shifter*.
- ⇒ The gear shift switches the gear.
- ⇒ The shifter returns to its original position.
- ▶ Clean the rear derailleur if the gear change blocks.

7.7

Brakes

**Crash caused by incorrect use**

Handling the brake improperly can lead to loss of control or crashes, which may result in injuries.

- ▶ Practice braking and emergency braking before the vehicle is used in public spaces.
 - ▶ Shift your weight back and down as far as possible.
-

**Crash caused by wet conditions**

The *tyres* may slip on wet roads. In wet conditions you must also expect a longer braking distance. The braking sensation differs from the usual sensation. This can cause loss of control or a crash, which may result in injuries.

- ▶ Ride slowly and brake in good time.
-

**Crash after cleaning, servicing or repair**

The braking effect may be unusually weak temporarily after cleaning, servicing or repairing the vehicle. Such damage may cause you to fall from the vehicle and injure yourself.

- ▶ After cleaning, servicing or repair, carry out a few test brake applications.
-

**Burns caused by heated brake**

The brakes may become very hot during operation. There is a risk of burns in case of contact.

- ▶ Never touch the components of the brake directly after the ride.
-

The drive force of the motor is shut off during the ride as soon as the rider no longer pedals. The drive system does not switch off when braking.

- ▶ In order to achieve optimum braking results, do not pedal while braking.

7.7.1 Braking

- ▶ Pull the *brake levers* until the desired speed has been reached.

7.8 Horn



Risk of an accident if power fails

The horn no longer works if the battery fails. You can no longer sound a warning in hazard situations. This may lead to an accident with serious injuries.

- ▶ Never ride the vehicle without a battery.
-

7.8.1 Sounding the horn

- ▶ Press on the horn button.
- ⇒ The horn sounds a warning.

7.9 Suspension and damping

7.9.1 Fork

When the *fork lock* is in the open position, the *suspension system* is active, thus reducing impact on the rider and the vehicle. You should therefore preferably ride with the *fork lock* open when on terrain.

The fork can only move slightly if the suspension is locked. This ensures the front tyre maintains contact with the ground without lifting when travelling over obstacles. This setting offers greater traction and better steering compared to opened suspension.

When riding downhill or at high speed, the *suspension system* absorbs the force exerted on the drive, reducing it by up to 50%. It is recommendable to close the suspension fork in such circumstances.

The *fork lock* is located on the fork head.



Figure 30: Fork lock with locking lever (1), which can be placed in the closed (2) or opened (3) position

7.9.1.1 Locking the fork lock

- If you wish to lock the *front wheel suspension*, push the *locking lever* clockwise and into the locked position.

7.9.1.2 Opening the fork lock

- ▶ If you wish to open the *front wheel suspension*, push the *locking lever* anti-clockwise and into the opened position.

7.10 Rear frame damper

7.10.1 Activating the threshold setting

The threshold or pedalling setting prevents the damper from deflecting when there are slight impact or downward forces. When riding downhill or at high speed, the *damper* absorbs and diminishes the force exerted on the drive. The threshold setting is recommended in such cases.

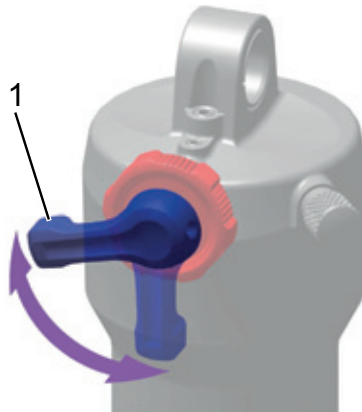

Figure 31: Activating the threshold setting with the lever (1)

- ✓ Only activate the threshold setting while the vehicle is stationary.
- ▶ Turn the lever into the threshold position indicated on the damper.

7.10.2 Activating the lock setting

The lock setting prevents the damper from deflecting until there is a strong impact or downward force. The

damper deflects if the acting force exceeds the damper's unlocking resistance.

The lock setting is optimum to maximise pedalling efficiency on flat or hilly terrain.

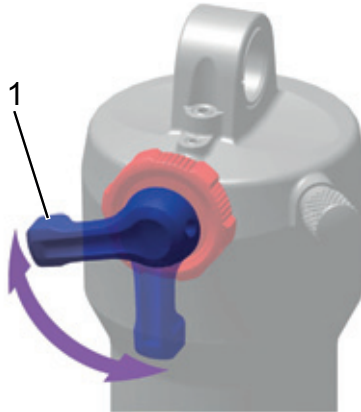

Figure 32:

Activating the threshold setting with the lever (1)

- ✓ Only activate the lock setting while the vehicle is stationary.
- ▶ Turn the lever in a clockwise direction until it reaches the end position.

7.1.1

Wheel

**Crash caused by unfastened quick release**

A faulty or incorrectly installed quick release may become caught in the brake disc and block the wheel. This will cause a crash.

- ▶ Install the front wheel quick release lever on the opposite side to the brake disc.
-

**Crash caused by faulty or incorrectly installed quick release**

The brake disc becomes very hot during operation. Parts of the quick release may become damaged as a result. The quick release comes loose. This will result in a crash and injuries.

- ▶ The front wheel quick release lever and the brake disc must be situated on opposite sides.
-

**Crash caused by incorrectly set clamping force**

Excessively high clamping force will damage the quick release and cause it to lose its function.

Insufficient clamping force will cause a detrimental transmission of force. The fork or frame may break. This will result in a crash and injuries.

- ▶ Never fasten a quick release using a tool (e.g. hammer or pliers).
 - ▶ Only use the clamping lever with the specified set clamping force.
-

7.1.1

Closing the quick release

- ▶ Place the quick release lever in the open position in the recess in the axle mouth.

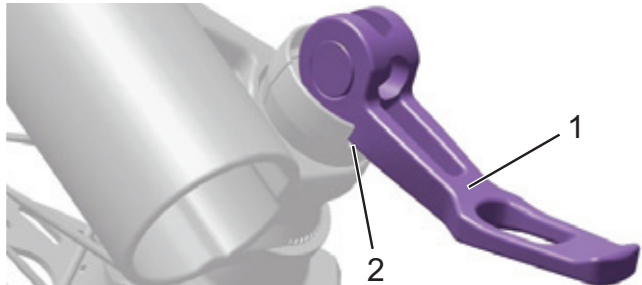

Figure 33:

Placing the quick release lever (1) into the recess (2)

- ▶ Fasten the quick release on the quick release lever by hand in a clockwise direction and into the fork base. Tighten it firmly in a horizontal position.

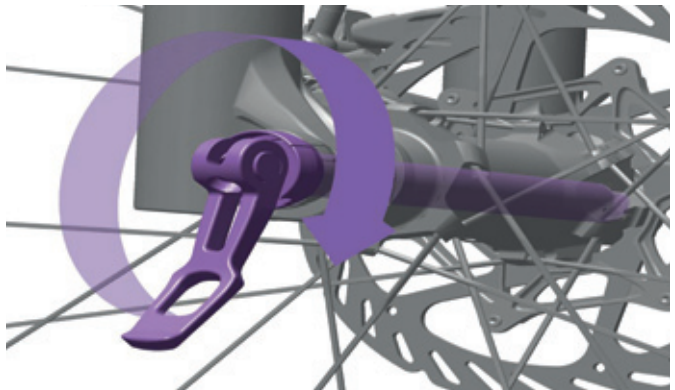

Figure 34:

Fastening the quick release

- ▶ Straighten the quick release lever and use two fingers to fasten the quick release. Move the quick release lever horizontally into the closed position.
- ⇒ The quick release is now fastened. The lever is sufficiently fastened if the lever leaves an impression on your hand.



Crash caused by adjusted quick release

The axle may come loose if the closed quick release is turned. This will result in a crash and injuries.

- ▶ Never adjust or turn a quick release after closing it, e.g. to correct the final position.

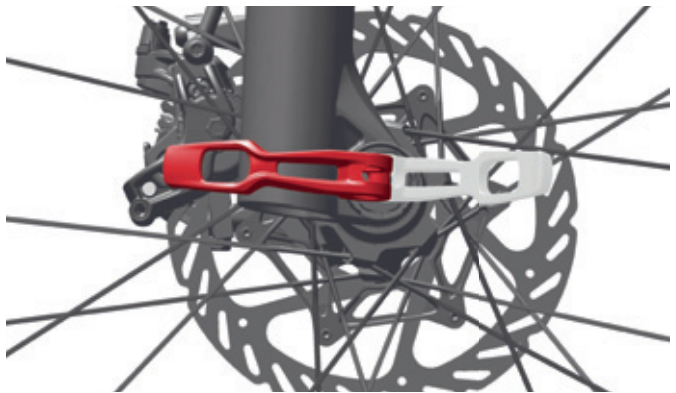

Figure 35:

Moving the quick release lever horizontally into the closed position

8

Maintenance**Cleaning check list**

<input type="checkbox"/>	Clean rear frame damper	after every ride
<input type="checkbox"/>	Clean front wheel fork	after every ride
<input type="checkbox"/>	Chain (mainly tarmacked road)	every 250–300 km
<input type="checkbox"/>	Chain (mainly off-road riding)	every 120–150 km
<input type="checkbox"/>	Clean the battery	once a month
<input type="checkbox"/>	Basic cleaning and preservation of all components	at least every six months
<input type="checkbox"/>	Clean the charger	at least every six months

Maintenance checklist

<input type="checkbox"/>	Check USB rubber cover position	before each ride
<input type="checkbox"/>	Check for tyre wear	once a week
<input type="checkbox"/>	Check for rim wear	once a week
<input type="checkbox"/>	Check the tyre pressure	once a week
<input type="checkbox"/>	Check for brake lining wear	once a week
<input type="checkbox"/>	Check electrical cables and Bowden cables for damage and ensure they are fully functional	once a month
<input type="checkbox"/>	Check the chain tension	once a month
<input type="checkbox"/>	Check the tension of the spokes	every three months
<input type="checkbox"/>	Check the gear shift setting	every three months
<input type="checkbox"/>	Torques for the rear frame damper fastening parts	every three months
<input type="checkbox"/>	Check the fork for wear and ensure it is fully functional	every three months

<input type="checkbox"/>	Check for wear on brake discs	at least every six months
--------------------------	-------------------------------	---------------------------

Inspection checklist

<input type="checkbox"/>	50-hour rear frame damper maintenance (air chamber maintenance)	50 hours
<input type="checkbox"/>	200-hour rear frame damper maintenance (maintenance of IFP chamber, damper body and piston. Venting of the rear frame damper)	200 hours
<input type="checkbox"/>	50-hour front wheel fork maintenance	50 hours
<input type="checkbox"/>	100-hour front wheel fork maintenance	100 hours
<input type="checkbox"/>	Half-yearly inspection by the specialist dealer	every six months
<input type="checkbox"/>	Drive unit inspection	15,000 km

8.1**Cleaning and servicing**

**Crash and falling caused by unintentional activation**

There is a risk of injury if the drive system is activated unintentionally.

- ▶ Remove the battery before cleaning.
-

The following servicing measures must be carried out regularly. Servicing can be performed by the user and rider. In case of any doubt, consult the ZEG specialist dealer.

8.1.1**After every ride****8.1.1.1****Cleaning the fork**

- ▶ Remove dirt and deposits on the stanchions and deflector seals with a damp cloth.
- ▶ Check the air pressure.
- ▶ Check the stanchions for scratches.
- ▶ Lubricate the dust seals and stanchions.

8.1.1.2**Cleaning the pedals**

- ▶ Clean with a brush and soapy water after riding through dirt or rain.
- ⇒ Service the pedals after cleaning.

8.1.2

Basic cleaning**Crash caused by brake failure**

The braking effect may be unusually weak temporarily after cleaning, servicing or repairing the vehicle. Such damage may cause you to fall from the vehicle and injure yourself.

- ▶ Never apply care products or oil to the brake discs or brake pads, or the braking surfaces on the rims.
- ▶ After cleaning, servicing or repair, carry out a few test brake applications.

NOTICE

Water may enter into the inside of the bearings if you use a steam jet. The lubricant inside is diluted, the friction increases and, as a result, the bearings are destroyed in the long term.

- ▶ Never clean the vehicle with a steam jet.

NOTICE

Greased parts, e.g. the seat post, the handlebars or the stem, may no longer be safely and reliably clamped.

- ▶ Never apply grease or oil to the clamping areas.

- ✓ Remove battery and display before basic cleaning.

8.1.2.1**Cleaning the frame**

- ▶ Soak the entire frame with dish-washing detergent if the dirt is thick and ingrained.
 - ▶ After leaving it to soak for a time, remove the dirt and mud with a sponge, brush and toothbrush..
 - ▶ Use a watering can or your hand to rinse the frame to finish off.
- ⇒ Service the frame after cleaning.

8.1.2.2**Clean rear frame damper**

- ▶ Clean rear frame damper with a cloth and washing water.

8.1.2.3**Cleaning the wheel**

Check the wheel for possible damage when cleaning the tyres.

- ▶ Use a sponge and a brush to clean the hub and spokes from the inside to the outside.
- ▶ Clean the rim with a sponge.

8.1.2.4**Cleaning the drive elements**

- ▶ Spray the cassette, the *chain wheels* and the front derailleur with a degreasing agent.
 - ▶ Clean coarse dirt with a brush after soaking for a short time.
 - ▶ Wash down all parts with dish-washing detergent and a toothbrush.
- ⇒ Service the drive elements after cleaning.

8.1.2.5

Cleaning the chain**NOTICE**

- ▶ Never use aggressive (acid-based) cleaners, rust removers or degreasers when cleaning the chain.
 - ▶ Do not use chain cleaning devices or chain cleaning baths.
-
- ▶ Slightly dampen a brush with dish-washing liquid. Brush both sides of the chain.
 - ▶ Dampen a cloth with dish-washing liquid. Place the cloth on the chain.
 - ▶ Hold with slight pressure while slowly turning the rear wheel, so the chain passes through the cloth.
 - ▶ If the chain is still dirty afterwards, clean it with WD40.
- ⇒ Service the chain after cleaning.

8.1.2.6

Cleaning the battery**Fire and explosion caused by penetration by water**

The battery is only protected from simple spray water. Penetration by water can cause a short circuit. The battery may self-ignite and explode.

- ▶ Never clean the battery with a high-pressure water device, water jet or compressed air.
 - ▶ Never immerse the battery in water.
 - ▶ Remove the battery from the vehicle before cleaning.
-
- ▶ Only clean the electrical connections of the battery with a dry cloth or brush.
 - ▶ Wipe off the decorative sides with a damp cloth.

8.1.2.7

Cleaning the brake

**Brake failure due to water penetration**

The brake seals are unable to withstand high pressures. Damaged brakes can fail and cause an accident with injury.

- ▶ Never clean the vehicle with a high-pressure water device or compressed air.
 - ▶ Take great care even when just using a hosepipe. Never point the water jet directly at the seal section.
-
- ▶ Clean brake and brake discs with a brush, water and dish-washing detergent.
 - ▶ Clean brake discs thoroughly with brake cleaner or spirit.

8.1.2.8

Cleaning the display

NOTICE

If water enters into the *display*, it will be destroyed.

- ▶ Never immerse the *display* in water.
 - ▶ Remove the *display* from the vehicle before cleaning.
-
- ▶ Carefully clean the *display* with a damp, soft cloth.

-
- 8.1.3 Servicing**
- 8.1.3.1 Servicing the frame**
- ▶ Dry frame after cleaning
 - ▶ Spray with care oil Clean off the care oil again after a short time.
- 8.1.3.2 Servicing the fork**
- ▶ Treat the dust seals with fork oil
- 8.1.3.3 Servicing the drive elements**
- ▶ Spray the cassette, the *chain wheels* and the front derailleur with a degreasing agent.
 - ▶ Clean coarse dirt with a brush after soaking for a short time.
 - ▶ Wash down all parts with dish-washing detergent and a toothbrush.
- 8.1.3.4 Servicing the pedal**
- ▶ Treat with spray oil after cleaning.
- 8.1.3.5 Servicing the chain**
- ▶ Grease the chain thoroughly with chain oil after cleaning.
- 8.1.3.6 Servicing the drive elements**
- ▶ Service front and rear derailleur articulated shafts and jockey wheels with Teflon spray.

8.2

Maintenance



Crash and falling caused by unintentional activation

There is a risk of injury if the drive system is activated unintentionally.

- ▶ Remove the battery before maintenance.
-

The following maintenance measures must be carried out regularly. They can be carried out by the user and rider. In case of any doubt, consult the ZEG specialist dealer.

8.2.1

Checking the wheel

8.2.1.1

Checking tyre pressure

NOTICE

If the pressure is too low in the tyre, the tyre does not achieve its load bearing capacity. The tyre is not stable and may come off the rim.

If the pressure in the tyre is too high, the tyre may burst.

- ▶ Check the tyre pressure
 - ▶ *Adjust the tyre pressure as necessary.*
-

8.2.1.2

Checking the tyres

- ▶ Check the *tyre wear*. The tyre is worn if the anti-puncture protection or the carcass cords are visible.
- ⇒ A ZEG specialist dealer needs to change the tyre if it is worn.

8.2.1.3**Checking the rims**

- ▶ Check the *rims* for wear. The rims are worn as soon as the black, all-round groove on the pad friction surface becomes invisible.
- ⇒ Worn rims must be replaced by a ZEG specialist dealer.
- ⇒ We recommend that you also replace the *rims* at the same time as every second brake lining replacement.

8.2.2**Checking the brake system**

The maintenance interval for the brake depends on the weather conditions and how frequent the vehicle is used.

If the vehicle is used under extreme conditions such as rain, dirt or high mileage, maintenance must be performed more frequently.

8.2.2.1**Checking for damage**

- ▶ Check brake linings and brake discs for cracks and deformation.
- ▶ Pull brake lever and hold several times and make sure that no oil leaks out from the brake system anywhere.
- ⇒ If a brake component should be damaged, it must be replaced by a ZEG specialist dealer immediately.

8.2.2.2**Checking the brake linings for wear**

Check brake linings after brake has been fully applied 1,000 times.

- ▶ Check that the brake lining is no less than 1.8 mm wide at any point and no less than 2.5 mm between the brake lining and supporting plate.

- ▶ Pull brake lever and hold. In doing so, check the transport safety wear gauge can fit between the brake lining supporting plates.
- ⇒ The brake linings have not reached their wear limit. If they had, a ZEG specialist dealer would need to replace them.

8.2.2.3 **Checking the pressure point**

- ▶ Pull brake lever and hold several times.
- ⇒ If you are unable to clearly detect the pressure point and it changes, a ZEG specialist dealer needs to vent the brake.

8.2.2.4 **Checking the brake discs for wear**

- ▶ Check that the brake disc is no less than 1.8 mm at any point.
- ⇒ The brake discs have not reached the wear limit. If they had, a ZEG specialist dealer would need to replace them.

8.2.3 **Checking the electrical cables and brake cables**

- ▶ Check all visible electrical cables and cables for damage. If the sheathing is compressed, for example, the vehicle needs to be removed from service until the cables have been replaced.
- ▶ Check all electrical cables and cables to make sure they are fully functional.

8.2.4 **Checking the gear shift**

- ▶ Check the gear shift and the *shifter* or the *twist grip* setting and adjust it as necessary.

8.2.5

Checking the chain tension

NOTICE

Excessive chain tension increases wear.

If the chain tension is too low, there is a risk that the *chain* will slip off the *chain wheels*.

- ▶ Check the chain tension once a month.
- ▶ Check the chain tension in three or four positions, turning the crank a full revolution.



- ▶ If the *chain* can be pushed more than 2 cm, the *chain* will need to be re-tensioned by a ZEG specialist dealer.
- ▶ If the *chain* can only be pushed up and down less than 1 cm, a ZEG specialist dealer needs to slacken the *chain* as required.

⇒ The ideal chain tension has been achieved if the *chain* can be pushed a maximum of 2 cm in the middle between the pinion and the toothed wheel. The crank must also turn without resistance.

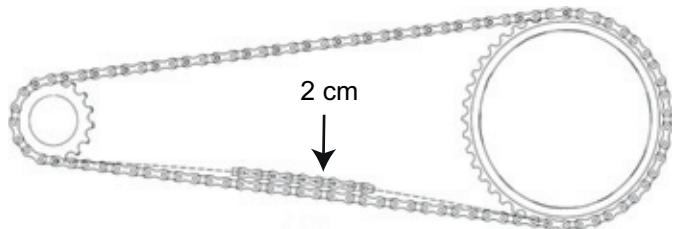

Figure 36:

Checking the chain tension

8.2.6

Checking the handlebar grip position

- ▶ Check the handlebar grip is firmly in position.

8.2.7**Checking the USB port cover**

NOTICE

Any moisture which enters through the USB port may trigger a short circuit in the *display*.

- ▶ Regularly check the position of the *cover on the USB port* and adjust it as necessary.
-

8.3

Service**Crash and falling caused by unintentional activation**

There is a risk of injury if the drive system is activated unintentionally.

- ▶ Remove the battery before the service.

**Crash caused by material fatigue**

If the service life of a component has expired, the component may suddenly fail. Such damage may cause you to fall from the vehicle and injure yourself.

- ▶ Have the ZEG specialist dealer carry out six-monthly basic cleaning of the vehicle, preferably at the same time as mandatory servicing work.

A service must be performed by the ZEG specialist dealer at least every six months. This is the only way to ensure that the vehicle remains safe and fully functional.



- ▶ The ZEG specialist dealer checks the vehicle for any signs of material fatigue during basic cleaning.
- ▶ The ZEG specialist dealer checks the software version of the drive system and updates it. The electrical connections are checked, cleaned and preservative agent is applied. The electrical cables are inspected for damage.
- ▶ The dealer maintains and services the vehicle. Particular attention is paid to the rim and brake wear. The spokes are re-tightened in accordance with the findings.

8.4 Adjusting and repairing

8.4.1 Use original parts and lubricants only

The individual vehicle parts have been carefully selected and matched to one other.

Only original parts must be used for maintenance and repair.

The constantly updated lists of approved accessories and parts are available to ZEG specialist dealers.

8.4.2

Rear frame damper

**Injury due to explosion**

The air chamber is pressurised. When the air system is serviced in a rear frame damper, it can explode and cause serious injury.

- ▶ Wear safety goggles, protective gloves and safety clothing when assembling or servicing the vehicle.
 - ▶ Release the air for the air chambers. Detach all air insert fitments.
 - ▶ Never service or dismantle a rear frame damper if it has not completely rebounded.
-

**Intoxication from suspension oil**

Suspension oil is toxic to the touch, irritates respiratory tracts and causes cancer, sterility and mutation in germ cells.

- ▶ Always wear safety goggles and nitrile gloves when carrying suspension oil.
 - ▶ Never perform maintenance when you are pregnant.
 - ▶ An oil catchment tray is positioned under the section where the rear frame damper is serviced.
-

**Hazard for the environment due to toxic substances**

The rear frame damper contains toxic and environmentally harmful oils and lubricants. These will contaminate if they enter the sewers or groundwater.

- ▶ Dispose of lubricants and oils left over after repairs in an environmentally responsible way in accordance with statutory regulations.
-



<https://www.bulls.de/service/downloads.html>

Special tools, special lubricants and knowledge of suspension components are required to maintain and repair the rear frame damper. The rear frame damper may become damaged if the procedure is not followed as described. Only ZEG specialist dealers may carry out maintenance on rear frame damper.

You will find the maintenance and repair instructions at:

www.sram.com/service

or

[bulls.de/service/downloads](https://www.bulls.de/service/downloads)

8.4.3

Fork

**Injury due to explosion**

The air chamber is pressurised. When an air system of a defective fork is serviced, it may explode and cause serious injury.

- ▶ Wear safety goggles, protective gloves and safety clothing when assembling or servicing the vehicle.
- ▶ Release the air for the air chambers. Detach all air insert fitments.
- ▶ Never service or dismantle a fork if it has not completely rebounded.

**Hazard for the environment due to toxic substances**

The suspension fork contains toxic and environmentally harmful oils and lubricants. These will contaminate if they enter the sewers or groundwater.

- ▶ Dispose of lubricants and oils left over after repairs in an environmentally responsible way in accordance with statutory regulations.



<https://www.bulls.de/service/downloads.html>

Special tools, special lubricants and knowledge of suspension components are required to maintain and repair forks. The fork may become damaged if procedures are not followed as described. Only ZEG specialist dealers may carry out maintenance on forks.

You will find the maintenance and repair instructions at:

<https://www.bulls.de/service/downloads.html>

8.4.4 Wheel quick release

8.4.4.1 Setting the clamping force

If the clamping lever cannot be pushed into its proper final position by hand, or if it is too loose, you need to readjust its clamping force.

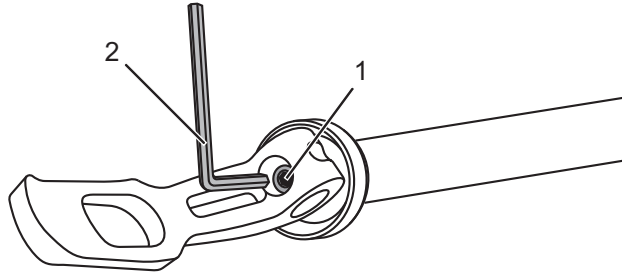

Figure 37: Setting the clamping force in the middle of the clamping lever (1) with a hexagon socket spanner (2)



The fork may become damaged if the procedure is not followed as described. Only ZEG specialist dealers may carry out maintenance on the clamping force.

- ▶ Open the quick release lever.
- ▶ Connect a 2.5 mm hexagon socket spanner to the middle of the clamping lever.
- ▶ Turn hexagon socket spanner until it clicks:
 - turn clockwise to increase the clamping force and
 - anti-clockwise to reduce the clamping force.
- ▶ Clamp the clamping lever.
- ▶ If the clamping lever is not yet in its final position, repeat the steps until the quick release is in a horizontal position.

8.4.5

Brake**Injury due to damaged brakes**

Special tools and specialist knowledge are required to repair the brakes. Incorrect or unauthorised assembly can damage the brakes. This may lead to an accident with injuries.

- ▶ Only ZEG specialist dealers may carry out repairs on brakes.
- ▶ Never carry out work or changes (such as dismantling, sanding or painting) which are not explicitly allowed and described in the brake user manual.

**Hazard for the environment due to toxic substances**

The brake system contains toxic and environmentally harmful oils and lubricants. These will contaminate if they enter the sewers or groundwater.

- ▶ Dispose of lubricants and oils left over after repairs in an environmentally responsible way in accordance with statutory regulations.



<https://www.bulls.de/service/downloads.html>

Special tools, special lubricants and knowledge of suspension components are required to maintain and repair brake discs, such as venting brakes or replacing the brake discs. The brakes may become damaged if procedures are not followed as described. Only ZEG specialist dealers may carry out maintenance on brakes.

You will find the maintenance and repair instructions at:

<https://www.bulls.de/service/downloads.html>

8.4.6 Lighting

8.4.6.1 Replacing the lighting



The ZEG specialist dealer must replace the entire light unit if an LED fails.

You will find the repair instructions at:
<https://www.bulls.de/service/downloads.html>

8.4.6.2 Setting the headlight

- ▶ The *headlight* must be set, so that its light beam meets the road 10 m in front of the vehicle.

8.4.7 Tyre

8.4.7.1 Adjust tyre pressure

- ✓ It is recommendable to use a bicycle pump with a pressure gauge. You must observe the bicycle pump operating instructions.
- ▶ Unscrew and remove the valve cap.
- ▶ Connect the bicycle pump.
- ▶ Pump up the tyre slowly and pay attention to the tyre pressure in the process.
- ⇒ The tyre pressure has been adjusted as per the data.
- ▶ Remove the bicycle pump.
- ▶ Screw the valve cap tight.
- ▶ Screw the rim nut gently against the rim with the tips of your fingers.

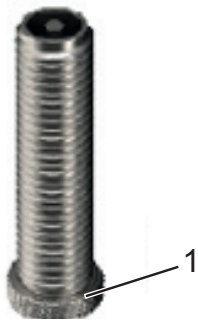

Figure 38: Schrader valve with rim nut (1)

8.4.7.2

Puncture and protect tyre

If a foreign body should cause a puncture, the tyre should be replaced and Schwalbe anti-puncture liquid should be used until it is replaced.

Anti-puncture liquids are useful for repairing small punctures when out and about without dismounting the tube or tyre. More serious damage such as cuts or snake bites cannot be repaired with anti-puncture liquids.

There are basically two different types of anti-puncture liquid:

The first type of liquid is purely mechanical. The liquid does not contain any fibres or particles which plug the hole. The advantage is that the liquid is unlimited in its effect. The disadvantage is that the hole is not really repaired. It is only plugged and may open up again – when pumping, for example.

The second fluid type is latex-based. The latex milk solidifies in the hole, repairing it permanently. Unfortunately, such liquids are only effective on the tube for a limited time as they harden at some point. Doc Blue anti-puncture liquid is effective as a remedy on tyres for about 2–7 months or about 2,000 km and offers additional protection for rides in extremely prickly or thorny terrain.

- ▶ Shake the anti-puncture liquid bottle well.
- ▶ Remove the valve insert.
- ▶ Fill 25–50 ml into the tube.
- ▶ Spin the wheel.

8.4.8

Repair by the specialist dealer



Special knowledge and tools are required for many repairs. Only a ZEG specialist dealer must carry out the following repairs, for instance:

- Replacing *tyres* and rims,
- Replacing the brake pads and brake linings,
- Replacing and tensioning the *chain*.

8.4.9

System messages**Fire and explosion due to faulty batteries**

The safety electronics on damaged or faulty batteries may fail. The residual voltage can cause a short circuit. The batteries may self-ignite and explode.

- ▶ Batteries with external damage must be removed from service immediately.
- ▶ Never allow damaged batteries to come into contact with water.
- ▶ If a battery is dropped or struck but shows no signs of external damage, remove the battery from service and observe it for at least 24 hours.
- ▶ Faulty batteries are hazardous goods. Dispose of faulty batteries properly and as quickly as possible.
- ▶ Store in a dry place until disposal. Never store in the vicinity of flammable substances.
- ▶ Never open or repair the battery.

The components of the drive system are checked constantly and automatically. If an error is detected, the respective error code appears on the *display*. The drive may be shut off automatically, depending on the type of error.

8.4.9.1**First aid**

If an error message is displayed, run through the following actions:

- ▶ Make a note of the system message.
- ▶ Shut off and re-start the drive system.
- ▶ If the system message is still displayed, remove and then re-insert the battery.
- ▶ Re-start the drive system.
- ▶ If the system message is still displayed, contact the ZEG specialist dealer.

8.4.9.2**Specific error eradication**

- ▶ Make a note of the system message.

Error	Remedy
10	▶ Charge the battery.
12	▶ Charge the battery.
24	Incorrect charger. ▶ Use the supplied charger for charging.
40, 41, 44	Overcurrent detected and motor overheating ▶ Relieve the motor with reduced pedalling or a lower assistance level.

Table 34:**Error eradication using the code**

- ▶ If the system message is still displayed, contact your ZEG specialist dealer.

8.4.10

First aid

8.4.10.1

Electrical drive system does not start

If the display and/or the drive system do not start up, proceed as follows:

- ▶ Check whether the battery is switched on. If not, start the battery.
- ⇒ If the LEDs of the charge status indicator do not light up, contact the ZEG specialist dealer.
- ▶ If the LEDs of the charge status indicator light up, but the drive system does not start up, remove the battery.
- ▶ Wait at least 30 seconds.
- ▶ Insert the battery.
- ▶ Start the drive system.
- ▶ If the drive system does not start up, remove the battery.
- ▶ Clean all the contacts with a soft cloth.
- ▶ Insert the battery.
- ▶ Start the drive system.
- ▶ If the drive system does not start up, remove the battery.
- ▶ Fully charge the battery.
- ▶ Insert the battery.
- ▶ Start the drive system.
- ▶ If the drive system does not start up, remove the display.
- ▶ Fasten the display.
- ▶ Start the drive system.

- ▶ If the drive system does not start up, contact the ZEG specialist dealer.

8.5

Accessories

Basic rules for attaching accessories

	Child seats	We strongly advise against fitting a child seat for safety reasons.
	Trailer	Not permitted
	Additional battery headlight	Not permitted
	Use of baskets	Not advisable
<input type="checkbox"/>	Non-permanently attached bags on the pannier rack	Permitted
<input type="checkbox"/>	Top cases on the pannier rack	Permitted

The following accessories are recommended:

<i>Description</i>	<i>Article number</i>
Protective cover for electrical components	080-41000 ff
Panniers, system component*	080-40946
Vehicle box, system component*	080-40947

Table 35:

Accessories

*System components are matched to the pannier rack and provide sufficient stability due to special transmission of force.

9

Recycling and disposal



Risk of fire and explosion

The safety electronics on damaged or faulty batteries may fail. The residual voltage can cause a short circuit. The batteries may self-ignite and explode.

- ▶ Remove batteries with external damage from service immediately and never charge them.
- ▶ If the battery becomes deformed or begins to smoke, keep at a safe distance, disconnect the power supply at the socket, and notify the fire service immediately.
- ▶ Never extinguish damaged batteries with water or allow them to come into contact with water.
- ▶ Faulty batteries are hazardous goods. Dispose of faulty batteries properly and as quickly as possible.
- ▶ Store in a dry place until disposal. Never store in the vicinity of flammable substances.
- ▶ Never open or repair the battery.



Chemical burns to the skin and eyes

Liquids and vapours may leak from damaged or faulty batteries. They can irritate the airways and cause burns.

- ▶ Avoid contact with leaked liquids.
 - ▶ Immediately consult a doctor in case of contact with the eyes or any discomfort.
 - ▶ In case of contact with the skin, rinse off immediately with water.
 - ▶ Ventilate the room well.
-



Hazard for the environment

The fork, rear frame damper and hydraulic brake system contain toxic and environmentally harmful oils and lubricants. These will contaminate if they enter the sewers or groundwater.

- ▶ Dispose of lubricants and oils in an environmentally responsible way in accordance with statutory regulations.

The vehicle, the battery, the display and the charger are recyclable materials. They have to be disposed of separate from the domestic waste in accordance with the valid legal regulations, and recycled.



Separate collection and recycling saves reserves of raw materials and ensures that all the regulations for protection of health and the environment are adhered to when recycling the product and/or the battery.

- ▶ Never dismantle the vehicle, fork, charger, battery, brake system or rear frame damper for disposal purposes.
- ▶ The vehicle, the display, the unopened and undamaged battery and the charger can be returned to any ZEG specialist dealer free of charge. Depending on the region, further disposal options may be available.
- ▶ Store the individual parts of the decommissioned vehicle in a dry place, free from frost, where they are protected from direct sunlight.

10

Appendix

10.1

Parts and repair list

Components	Part	Repair instructions
Fork	RockShox Yari RC Solo Air suspension fork	www.sram.com/de/ service
Display	Brose, BLOKS CI	www.brose-ebike.com/ de/service/
Motor	Brose	www.brose-ebike.com/ de/service/
Front and rear brakes	Magura MT-5E hydraulic disc brakes	www.magura.com/de/ components/ techcenter
Brake disc	Magura Storm HC Ø 203 mm	www.magura.com/de/ components/ techcenter
Brake lever	Magura MT5E brake lever	www.magura.com/de/ components/ techcenter
Brake pads	Magura, Type 9.P Performance	www.magura.com/de/ components/ techcenter
Hub, front	Formula, DC-711, ALLOY ANODIZED, 6- BOLT TYPE, BOOST 110 mm 14 Gx32 H	www.formulahubs.com /contact
Front and rear rims	BULLS AS-T35 rims tubeless ready	service@zeg.de
Spokes, front	BULLS STAINLESS BLACK, 14Gx32H;	service@zeg.de
Front and rear tyres	Schwalbe Nobby Nic Snake Skin TLE Apex Addix Spgrip tyres	www.schwalbe.com/ en/kundenservice.html
Hub, rear	FORMULA, EHL-148S, ALLOY S.B. MATT BLACK, 6-BOLT BOOST 148 mm 4SB, 13Gx32H,	www.formulahubs.com /contact
Spokes, rear	STAINLESS BLACK, REAR:13Gx32H	service@zeg.de

Table 36:

Type number, model and vehicle type categorisation

Components	Part	Repair instructions
Pinion	SHIMANO, CS-M8000-11, 11-SPD, 11-40T	si.shimano.com/#/en/search/Series
Crank	MIRANDA CLASSIC, BROSE 170 MM; Q12 ISIS; BLACK MATT; # PD 22 IBT 17 CA 700001500	service@zeg.de
Chainring set	Shimano 44/30 T	si.shimano.com/#/en/search/Series
Pedals	Wellgo C122-B pedals	en.wellgopedal.com/download_list.php?cid=2
Chain	KMC, X11E, NP/NP	service@zeg.de
Derailleur	Shimano DEORE RD-T780	si.shimano.com/#/en/search/Series
Front derailleur	Shimano DEORE RD-T780	si.shimano.com/#/en/search/Series
Cassette sprockets	Shimano CS-M8000 11 40-T	si.shimano.com/#/en/search/Series
Shifter	Shimano SL - M8000	si.shimano.com/#/en/search/Series
Saddle	Selle Royal Look-In Moderate saddle	www.selleroyal.com/en/support-cyclists
Seat post	Kalloy sp 719	kalloyuno.imb2b.com/contact/
Fork	RockShox Yari RC Solo Air suspension fork	www.sram.com/de/Service
Rear frame damper	RockShox Deluxe RT rear frame damper	supernova-lights.com/service/tutorials
Rear light	Supernova M99-E6	supernova-lights.com/service/tutorials
Rear reflector	Supernova, ECE rear reflector, #P-K114E-RED-3M-08, fitting onto number plate/holer	supernova-lights.com/service/tutorials
Headlight	BUSCH MÜLLER IQ-X	www.bumm.de/de/products.html

Table 36: Type number, model and vehicle type categorisation

Components	Part	Repair instructions
Side reflector	BUSCH & MÜLLER, #306/2KG-1, MOUNTON FORK	www.bumm.de/de/ products.html
Kickstand	HEBIE, #0665 E, E FIX 18,	service@zeg.de
Registration plate holder	ZEG supply	service@zeg.de
Stem	BULLS stem	service@zeg.de
Handlebars	BULLS handlebars	service@zeg.de
Handles	TOPEAK/ERGON, GA30 BLACK, #43400090	service@zeg.de
Rear mirror	POLY AUTO TECHNOLOGY, FUXON M-1 MIRROR,	service@zeg.de
Horn	Busch und Müller horn, #660	www.bumm.de/de/ products.html

Table 36: Type number, model and vehicle type categorisation

10.2 Table of figures

Figure 1:	Type plate, example, 14
Figure 2:	Vehicle on the right – E-Stream Evo 45 AM, 19
Figure 3:	Detailed view of vehicle from rider position, example, 20
Figure 4:	Wheel components, example of front wheel, 21
Figure 5:	Vehicle without suspension (tension load) and with suspension (2) when riding over an obstacle, 22
Figure 6:	Yari fork – diagram with control elements: Air valve (1), valve cap (2) fork lock (3), quick release (4) and rebound damper adjuster (5) and the assembly groups: Air suspension fork (A), compression damper assembly group (B) and rebound damper assembly group (C), 24
Figure 7:	Exploded view drawing of RockShox Deluxe RT rear frame damper, 25
Figure 8:	Vehicle brake system with a disk brake, example, 26
Figure 9:	Diagram of drive system, 27
Figure 10:	Diagram of electric drive system, 28
Figure 11:	Display details with its indicator (1) and USB port (2), 30
Figure 12:	Overview of the screen displays , 31
Figure 13:	Overview of the command console, 34
Figure 14:	Integrated battery details, 36
Figure 15:	Fastening the transport securing device, 48
Figure 16:	Detail view of seat posts for seat post I (2) and seat post II (3), examples of the minimum insertion depth mark with minimum mark (4) and bar marking (1), 56
Figure 17:	Determining the saddle height, 57
Figure 18:	Seat post (2) quick release in the clamping lever end position on the seat post (1) and its knurled nut (3), 57
Figure 19:	Using the twist knob (1) to adjust the pressure point, 59
Figure 20:	Using the setting screw (2) to adjust the distance from the brake lever to the handlebar grip (1), 60
Figure 21:	Fork lock with floodgate adjuster (1), 64
Figure 22:	Rear frame damper with air valve cap (1) and valve (2), 65
Figure 23:	On deflection (arrow), the O ring (1) is pushed downwards away from the seal (2)., 66
Figure 24:	Rebound damper setting bolt (2) at the fork base (1), 68
Figure 25:	Setting the rebound damper strength on the rear frame damper setting wheel (1), 69
Figure 26:	Setting the compression damper, 70

-
- Figure 27: Setting the compression damper strength using the rear frame damper setting lever (1), 71
- Figure 28: Attach display (1) to the mount (3) by turning it in the direction of rotation indicated by the arrow (2), 84
- Figure 29: Down shifter (1) and up shifter (2) on the left (I) and right (II) shift, 88
- Figure 30: Fork lock with locking lever (1), which can be placed in the closed (2) or opened (3) position, 91
- Figure 31: Activating the threshold setting with the lever (1), 92
- Figure 32: Activating the threshold setting with the lever (1), 93
- Figure 33: Placing the quick release lever (1) into the recess (2), 95
- Figure 34: Fastening the quick release, 95
- Figure 35: Moving the quick release lever horizontally into the closed position, 96
- Figure 36: Checking the chain tension, 108
- Figure 37: Setting the clamping force in the middle of the clamping lever (1) with a hexagon socket spanner (2), 115
- Figure 38: Schrader valve with rim nut (1), 117

10.3 List of tables

Table 1:	Identification number of the operating instructions, 8
Table 2:	Type number and model categorisation, 8
Table 3:	Meanings of the signal words, 10
Table 4:	Safety markings on the product, 11
Table 5:	Information on the type plate, 11
Table 6:	Simplified terms, 12
Table 7:	Conventions, 12
Table 8:	Display technical data, 30
Table 9:	USB port technical data, 31
Table 10:	Overview of the screen display, 31
Table 11:	Levels of assistance screen, 32
Table 12:	Journey information, 33
Table 13:	Changeable system settings, 33
Table 14:	Overview of the command console, 34
Table 15:	Battery technical data, 35
Table 16:	Vehicle technical data, 37
Table 17:	Battery technical data, 37
Table 18:	Display technical data, 38
Table 19:	Emissions from the vehicle*, 38
Table 20:	USB port technical data, 38
Table 21:	Oil volume and lubricant for the fork, 39
Table 22:	Fork filling pressure table, 40
Table 23:	Deflection, Bottomless Tokens, 40
Table 24:	Floodgate table, 41
Table 25:	Brake technical data, 41
Table 26:	Tyres technical data, 42
Table 27:	Headlight technical data, 42
Table 28:	Tightening torque values, 43
Table 29:	Storage temperature for the battery, vehicle and charger, 49
Table 30:	Working environment temperature, 51
Table 31:	Handlebars clamping screw maximum tightening torque, 58
Table 32:	Air fork tyre pressure table, 62
Table 33:	Floodgate table, 65
Table 34:	Error eradication using the code, 121
Table 35:	Accessories, 124
Table 36:	Type number, model and vehicle type categorisation, 127

10.4 Index

- A**
 Air chamber, 25
 Air valve
 Fork, 24
 Rear frame damper, 25
- B**
 Basic cleaning, 101
 Battery lock,
 Position, 36
 Battery, 35
 - charging, 80
 - checking, 55
 - cleaning, 102
 - eliminating charging errors, 120
 - waking, 82
 Position, 19, 28, 36
 Technical data, 37
 Belt tension, 108
 Brake caliper, 26
 Brake disc,
 Position, 26
 Brake lever,
 - adjusting the pressure point 59
 - setting the grip distance, 60
 Position, 20
 Brake light, 35
 Position, 19, 28
 Brake lining,
 Position, 26
 Brake, 26
 - retracting brake linings, 71
 - using the transport securing system, 48
 Position, 26
 Technical data, 41
 Break in operation, 49
 - carrying out, 50
 - preparing, 50
- C**
 Chain drive, 27
 Chain guard,
 - checking, 75
 Chain tension, 108
 Chain wheel, 27
 Chain, 27
 - cleaning, 101, 104
 - maintaining, 108
 - replacing, 119
 position 19
 Charge status indicator, 36
 Checklist,
 Initial commissioning 54
 Clock,
 Screen position, 33
 Time format, 33
 Command console, 34
 Position, 20
 28
 Compression damper, see Rebound damper
- D**
 Damper, 22
 Damping, 22
 Compression damper, 22
 Rebound damper, 22
 Deflection,
 Bottomless Tokens, 40
 Direction of travel, 27
 Display, 30
 - attaching, 84
 - cleaning, 103
 - removing, 84
 Position, 20, 28
 Technical data, 38
 Drive system, 27
 - switching off, 83
 - switching on, 83
- E**
 Error message, see System message,
 EU type-approval number 14
- F**
 Filling pressure table
 Fork, 40
 Fork lock,
 - setting, 64
 Position, 24
 Fork, 22
 - adjusting sag, 63
 - adjusting tyre pressure, 62
 - fork lock, 64
 - setting the compression damper, 70
 Floodgate table, 41
 Fork end, 21
 Position, 19
 Setting the rebound damper, 68
 structure, 24
 Technical data, 39
 Frame, 19
 Front wheel brake, 26
 - braking, 90
 Front wheel, see Wheel
 Function screen, 32
 Position, 31
- G**
 Gear shift twist grip,
 - checking, 107
 Gear shift,
 - maintaining, 107
 - switching, 88
- H**
 Handlebars, 20
 - setting, 58
 Position, 19
 Headlight, 29
 Position, 19, 20, 28
 Technical data, 42
 Horn, 29
 Position, 20, 28
 Hub, 21
- I**
 Info button,
 Position, 34
 Initial commissioning, 53
- J**
 Journey information, 32
 - resetting, 87
 - switching, 86

- K**
Kickstand, 19
- L**
Level of assistance, 32
- selecting, 86
Screen position, 31
Lever, 25
- M**
Manufacturer, 14
Minimum insertion depth marking, 56
Minus button, Position, 34
Mirror, 20
Model, 8
Motor power, 14
Motor, Position, 28
Mudguards, - checking, 75
- N**
Nameplate 14
Nameplate, Position, 19
- O**
On-Off button, Battery position, 36
Command console position, 34
Operating and charge status indicator, 36
Position, 36
O-ring, 25
- P**
Packaging, 52
Pannier rack, - checking, 75
Pedal, 27
Plus button, Position, 34
Port for charger plug
Position, 36
Push assist button, Position, 34
Push assist, 28
- using, 85, 86
- Q**
Quick release, Position, 24
- R**
Rear frame damper, - adjusting sag, 66
- adjusting tyre pressure, 65
- setting the rebound damper, 69
structure, 25
Rear light, 35
Position, 19, 28
Rear wheel brake, 26
Rear wheel damper, - setting the compression damper, 71
Rear wheel, see Wheel
Rebound damper adjuster, Position, 24
Rebound dashpot, see Rebound damper
Reflector, 19
Registration plate, 19
Reset all, 33
Position, 33
Reset trip, 33
Position, 33
- Rim,**
- checking, 106
- replacing, 119
Position, 21
Running light, - checking function, 75
- S**
Saddle, 56
- adjusting the seat position 58
- changing the saddle tilt, 58
- changing the seat length, 58
- clamping the seat post tight, 57
- clamping, 57
- determining the saddle height, 56
- determining the seat height. 56
Position, 19
Screen display, 31
Seat post, Position, 19
Setting wheel, 25
Shifter, - checking, 107
- setting, 110, 117
Position, 20
Shock absorber, 21
Speed, 32
Average, 33
Maximum, 33
Screen position, 31
Top speed, 14
Spoke, 21
Stem, Position, 19
Storage, 48
Storing, see Storage
Suspension fork, 22
Suspension head, 21
Suspension, 22
- setting, 61
System message, 34
- understanding, 120
System setting, 33
- T**
Tightening torque values, 43
Total distance, 33
Position, 33
Total time 33
Position, 33
Transportation, 46

Transporting, see
Transportation
Trip calories, 33
 Position, 33
Trip distance, 33
 Position, 33
Type number, 8
Tyres,
 - checking, 105
 - replacing, 119
 Position, 21
 Technical data, 42

U

USB port, 31
 - using, 85
 Position, 30
 Technical data, 38

V

Valve cap, 24
Valve, 21
 Position, 21
Vehicle class 14
Vehicle identification number,
14
 Position, 19
Vehicle stand, see kickstand

W

Warning,
 Position, 31
Weight, 37
 Maximum gross load
 weight, 37
 permitted total weight, 14
Wheel,
 - maintaining, 105
Winter break, see break in
operation
Working environment, 51

Text and images:
ZEG Zweirad-Einkaufs-Genossenschaft eG
Longericher Strasse 2
50739 Köln, Germany

Translation:
Tanner Translations GmbH+Co
Markenstrasse 7
40227 Düsseldorf, Germany

Operating instructions: 34-03141_1.0_11.06.2018



WWW.BULLS.DE

ZEG Zweirad-Einkaufs-Genossenschaft eG
Longericher Straße 2
50739 Köln, Germany
Tel.: +49 221 17959 0

YOUR BULLS SPECIALIST DEALER

